

# FILTERS AND SEPARATORS PRODUCT PROGRAMME



DEDICATED TO CLEAN AIR

# Sales, delivery and payment terms

## 1. Applicability

Applicability: These sales, delivery and payment terms (hereinafter "the Terms") apply to all offers, orders and deliveries supplied by JKF Industri A/S, CVR no. 17085204 (hereinafter "JKF") to any business customer (hereinafter "the Buyer") (hereinafter collectively referred to as "the Parties"), unless expressly agreed otherwise.

JKF cannot be bound by terms applied by the Buyer, including purchasing terms, even if JKF has not objected to such terms.

## 2. Information in sales materials and price lists

Details given in JKF's brochures, advertising, product descriptions, price lists etc. on capacity, resistance to wear, performance, technical data, dimensions, weight or the like are not binding on JKF. We cannot be held responsible for printing errors and model changes.

## 3. Quotes

All quotes are given subject to the goods being unsold. If JKF provides a quote that does not stipulate a specific time for acceptance, the quote will expire automatically if the Buyer's confirmation is not received by JKF within 30 days of the date of the quote.

## 4. Prices

All prices are in DKK and ex-VAT, customs and other duties, packaging, freight costs and insurance and all other costs to be borne by the customer.

Prices are stated in EUR exclusive of the aforementioned costs for Buyers located in countries, which are members of the European Economic and Monetary Union (the Euro).

Unless otherwise stated on JKF's quote or order confirmation, JKF reserves the right to revise prices – even after issuing and order confirmation – in the event of increased production costs and the like.

All orders worth less than DKK 1500 (excluding the above costs) are subject to an administration fee of DKK 225.

## 5. Payment terms

JKF is entitled to issue an invoice when delivery is complete. Payment terms are current month + 20 days net calculated from the date of invoice unless otherwise agreed in writing.

JKF obtains credit insurance for all customer receivables. If the Buyer's credit fails to be approved, JKF is entitled to demand prepayment or alternative guarantee.

If payment is made after the due date and the delay is no fault of JKF, JKF is entitled to charge interest on the sum outstanding as from the due date, at a rate equivalent to 2% per month or part thereof.

The Buyer is not entitled to offset any counter-claims against JKF unless expressly agreed in writing by JKF, and does not have the right to withhold any of the purchase sums by reason of counter-claims of any kind.

## 6. Right of ownership

### For Buyers in the United Kingdom:

The goods shall remain the property (i.e. title) of JKF until: (i) the full price for them is paid; and (ii) all sums for any other goods or services then properly due and payable from the Buyer are paid to JKF. JKF may at any time attribute any money received by it from the Buyer in any order as JKF may decide. Until such payment, the Buyer shall hold the goods on a fiduciary basis as the bailee or depository of JKF, and shall not dispose of them. However, subject to JKF's prior written consent, the Buyer may on the Buyer's own account sell the goods to any customers but shall not do so after any step is taken or made for any composition or arrangement with creditors generally, liquidation, winding-up, dissolution, administration, receivership or bankruptcy of the Buyer.

If any such step occurs, or JKF reasonably expects that such a step is soon to occur, or any payment due to JKF from the Buyer becomes overdue, JKF may by written notice terminate the Buyer's right (if any) to sell the goods and JKF may then recover such goods and for that purpose enter any premises, subject to the Buyer's continued liability to pay the price for the goods. If the item has been sold with a view to later being built into or joined to other objects, the item sold is not covered by the right of retention once such installation or joining has taken place.

JKF reserves the right within the limitations of mandatory laws to retention of title to the item sold until payment for the entire purchase sum, plus any costs incurred, has been made to JKF. If the item has been sold with a view to later being built into or joined to other objects, the item sold is not covered by the right of retention once such installation or joining has taken place.

### For Buyers outside the United Kingdom:

JKF reserves the right within the limitations of mandatory laws to retention of title to the item sold until payment for the entire purchase sum, plus any costs incurred, has been made to JKF. If the item has been sold with a view to later being built

into or joined to other objects, the item sold is not covered by the right of retention once such installation or joining has taken place.

## 7. Delivery

The delivery clause agreed between the Parties is to be interpreted in accordance with the INCOTERMS current at the time of signing the agreement.

The delivery date is set by JKF according to best judgement, and if it cannot be observed, the Buyer will be informed accordingly, with when, as far as possible, delivery can be expected to take place. Any delay does not give the Buyer the right to cancel the sale and/or claim any form of financial compensation from JKF.

## 8. Packaging

All orders are subject to a packaging fee of 2.2 % of the order value.

Packaging may only be returned by prior written agreement. Return of packaging is at the Buyer's own expense and risk. The Buyer's packaging will be credited when received and upon final approval by JKF that it is in much the same condition as when delivered to the Buyer.

## 9. Product information and confidentiality

All illustrations, technical drawings and brochures issued by JKF before or after the contract have been entered into remain the property of JKF and must be returned to JKF on request. Such materials must be treated with strict confidentiality and cannot be used, copied or passed on without written agreement, or abused in any other manner.

The Buyer undertakes to generally observe confidentiality concerning all aspects of JKF known to the Buyer as a result of the information the Parties have exchanged in the course of their dealings.

Breach of this provision by the Buyer shall incur a fine payable to JKF of DKK 75,000. The fine shall be payable for each breach of the provision, and if the breach consists of continuation of a previous breach, the fine shall be payable for each 14 day period of continuation or part thereof. Payment of a fine shall not relieve the Buyer of the above obligations, nor prevent or constrain JKF from claiming compensation for any loss JKF may have incurred arising from the breach, in that payment of the fine by the Buyer shall not be included in calculation of JKF's loss. In addition to the above, JKF is entitled to take out an injunction.

## 10. Liability for defects and deficiencies and warranty claims

Upon delivery, the Buyer shall immediately perform a thorough examination of the goods, including quantity and specifications.

Should the Buyer wish to claim for any defects or deficiencies, including with regard to the quantity or specifications delivered, which the Buyer has or should have discovered in the course of thorough examination of the goods, a written claim shall be submitted to JKF immediately after delivery. JKF is entitled to reject any claims received after the expiry of the deadline stated above.

JKF warrants performing redelivery/remedy of goods which are defective or deficient due to material or manufacturing error for goods which the Buyer has not nor should have discovered by thorough examination for a period of 12 consecutive months after delivery.

However, the Buyer shall submit a claim to JKF immediately if discovering such defects or deficiencies.

Defective or deficient goods will either be remedied or replaced within a reasonable period of time at JKF's discretion. Modification/interference with the goods without JKF's written consent releases JKF from any obligation.

Remedy/redelivery by JKF of elements of a delivery shall be on the same terms and conditions as for the original delivery, including those stated in item 7. JKF's obligation to remedy or redeliver does not, however, apply to any part of an order more than 1 year after delivery to the Buyer.

Once liability for the order has been transferred to the Buyer, JKF bears no responsibility for any defects over and above the obligations specified in this provision.

## 11. Force majeure

JKF cannot be held liable for non-fulfilment of its undertakings, nor for loss incurred by the Buyer due to unusual circumstances that prevent, inhibit or add extra cost to fulfilment of the contract, and that are beyond JKF's control, including industrial disputes, strikes, lockout, fire, war, mobilisation, unforeseen military call-up, acts of sabotage, requisitioning, confiscation, currency restrictions, import ban, export ban, riots, unrest, extreme weather conditions, fuel shortage and major increases in prices or taxes/duties, general scarcity of goods, restrictions in power supplies and defects in deliveries from sub-suppliers or delays with such deliveries as a result of any

of the aforementioned circumstances.

It should be specifically noted that the above is not an exhaustive list of examples, and there may be other examples that come under limitation of liability.

If delivery is temporarily delayed by one or more of the aforementioned circumstances, the delivery date will be correspondingly postponed. If delivery is prevented for more than 12 weeks, JKF is entitled to cancel the relevant contract without liability.

## 12. Returns

Items sold can only be returned by prior written agreement, and upon obtaining a returned goods order number. Returns will be at the Buyer's expense and risk and should include JKF's invoice number and the date of the original delivery.

Returned goods will only be credited by prior agreement and subject to approval of the goods returned. Custom-made goods will not be credited. If JKF is charged for shipping costs etc., JKF is also entitled to demand these be refunded by the Buyer and to offset these against any claims by the Buyer against JKF.

## 13. Product liability

JKF's product liability is subject to the rules of Danish law on product liability with the limitation specified in item 12 (limitation of indirect loss and of cover in accordance with insurance cover).

**JKF cannot be held liable for operating loss, loss of profit, loss of useful value, loss of business opportunities, lost savings or other indirect loss or consequential damages in connection with product liability.** To the extent that product liability may be imposed on JKF with regard to third parties, the Buyer is obliged to compensate JKF to the same extent that JKF's liability is limited as per the above. These limitations to JKF's liability do not apply if JKF is guilty of gross negligence. If a third party puts forward a claim against one of the Parties for compensation with reference to this point, that party must immediately inform the other party. The Buyer can be sued at the same court that handles any claims for compensation against JKF, in consequence of damage alleged to have been caused by one of JKF's deliveries. JKF's liability for product damage shall always be limited to the remaining insurance cover.

## 14. Limitation of liability

**Notwithstanding the above, JKF cannot be held liable for any indirect loss such as operating loss, loss of profit, loss of useful value, loss of business opportunities, lost savings, consequential loss, loss of time etc., which a defect or deficiency could cause the Buyer or a third party, including indirect loss etc., arising as a result of delayed delivery or defects/deficiencies in the goods sold.**

## 15. Invalidity

Should one or more of the provisions in these terms be deemed invalid, illegal or non-applicable, the validity, legality or applicability of all other provisions shall not be affected or lessened as a result thereof.

## 16. Jurisdiction and court of venue

All disputes between the parties shall be settled under Danish law including the Danish Sale of Goods Act, but with the exception of Danish jurisdiction rules. The International Sale of Goods Act (CISG) shall neither be wholly nor partially applied.

Any dispute regulated by the terms shall be resolved by arbitration at the Danish Institute of Arbitration, according to the institute's rules, which apply when an arbitration case is brought with the amendments stated below.

However, the Parties agree that the arbitration tribunal shall consist of 3 members, of whom each party will appoint one member, and the Danish Institute of Arbitration will appoint the tribunal chairman. If a party fails to appoint a member within 14 days of being requested to do so by the Danish Institute of Arbitration, the institute will appoint a member on behalf of that party.

The tribunal shall sit in Hadsund.

The original version of this document is in Danish. In the event of discrepancies between the Danish and English versions, the Danish version will take preference.

## Content

### General 00

JKF filters .....	Page 4
Discharge systems .....	Page 6
Cleaning systems .....	Pages 7-8
ATEX explosion relief venting .....	Pages 9-10
Ladders and gangways .....	Page 11
Filter selection .....	Pages 12-13

### Filters 01

SuperBlower-filter .....	Pages 14-17
Blower- og EC-filter .....	Pages 18-23
DustStorm®-filter .....	Pages 24-27
Jetline® K-filter .....	Pages 28-29
Jetline® CH-filter .....	Pages 30-31
Poluclean® SI-filter .....	Pages 32-33
SuperJet-filter .....	Pages 34-35
MMBF-filter .....	Pages 36-38

### Modular filters 02

Modular filters .....	Page 39
Silo filter type PL-PLD .....	Page 40
Blow through filter type L-LD .....	Page 41
Bag emptying filter type LS-LSD .....	Page 42
Rotor filter type HL-HLD .....	Page 43
Screw filter type S-SD .....	Page 44
Chain filter type CDF .....	Page 45
Point filter type PKF .....	Page 46
Intake filter .....	Page 47
Movable dust filters type JK-12 TS, JK-20 TS, JK-22 TS and JK-25 TSD .....	Page 48

### Accessories 03

Accessories .....	Page 49
Rotary valves type JK-S/JK-EXS .....	Page 50
Rotary valves type B-S/B-EXS .....	Page 51
EXS .....	Page 52
Cast-iron rotary valve type JK-T .....	Page 53
Separator .....	Pages 54-55
Cutter .....	Page 56
Combination valve .....	Page 57
Filter media .....	Pages 58-59
Cyclone type CS .....	Page 60
Cyclone type JA .....	Page 61
Big bag-solution .....	Page 62
Dust bucket .....	Page 63
Explosion duct valve .....	Page 64-65

## JKF filters



### Filters

JKF Industri has an extensive range of bag and cartridge filters, ranging from extraction from a single machine using a portable vacuum cleaner to traditional modular filter solutions and advanced round, welded and SuperBlower filters.

As such, JKF filters are particularly effective at filtering practically any form of dry material for any form of production facilities with the right filter media.

The filter range includes:

- SuperBlower filters
- Blower filters
- DustStorm® filters
- SuperJet filters
- MMBF filters
- Modular filters
- Intake filters
- Point filters
- Movable dust filters

### Surface treatment

JKF has installed a state-of-the-art automatic 3-zone powder coating plant, which ensures high, uniform quality on all painted items (W0.5xH2.0xL1.0 m). A powder coating plant

for larger items (W2.5xH2.5xL5.0 m) is used with integrated sandblasting facility. Powder application is manual.

### Benefits of powder coating:

- High quality, impact and scratch-resistant surface
- High material usage - no evaporation
- Environment protection - no solvents

### Standard surface treatment:

Filters, cyclones, fans, rotary valves, diverters:

3-step iron phosphate finish or sandblasting SA $\geq$ 2.5/  
Ra 6-10  $\mu$ m

Powder coated with primer 60-80  $\mu$ m (Interpon BPP600) and top coat paint 60-80  $\mu$ m (Interpon D1036 Gloss (85)) RAL 5010

Expected service life in corrosive environments corresponding to C3 is up to 15 years.

Ducts and other parts for duct systems:

3-step iron phosphate finish or sandblasting SA $\geq$ 2.5/  
Ra 6-10  $\mu$ m

Powder coated with top coat paint 60-80  $\mu$ m (Interpon D1036 Gloss (85)) RAL 7032

Expected service life in corrosive environments corresponding to C2 is up to 15 years.

### Customised surface treatment

Sandblasting SA $\geq$ 2.5/Ra 6-10  $\mu$ m.

Powder coated with primer 60-120  $\mu$ m (Interpon BPP600) and top coat paint 70-120  $\mu$ m (Interpon D1036 Gloss (85)) other RAL colours are available.

Expected service life in corrosive environments corresponding to C4 is up to 15 years.

### Quality

JKF believes strongly in quality management of all aspects from product development to production and order management. Our quality management system is certified according to DS/EN ISO 9001:2015.

### Working environment

JKF is certified according to DS/EN ISO 45001:2018 and continuously strives to improve health and safety at work.

### The environment

JKF constantly strives to develop methods and products which save energy and protect the environment. The company's environment management system is certified according to DS/EN ISO 14001:2015.

## JKF filters

### JKF filters in general

A filter basically consists of an inlet element, the filter, a cleaning system and a discharge element.

### Inlet

Depending on type, filters can be supplied with 3 different inlet elements, each with their own characteristics, benefits and areas of use.

- Tangential inlet
- Air supply chamber
- Side inlet, settling chamber
- Side inlet, partial downflow

### Tangential inlet

Tangential inlet is the most common type. Contaminated air is passed tangentially to the cylindrical filter body. Particles will be thrown outwards towards the outside of the shell by centrifugal force and accelerated, pressing them together. They will then drop to the bottom of the filter.

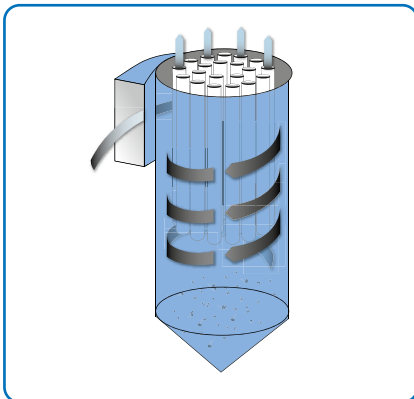

*Tangential inlet*

### Air supply chamber

The air supply chamber passes contaminated air into a settling chamber, which in principle is a widening of the conduit diameter - possibly with baffles and guide plates fitted. The velocity of the contaminated air is reduced due to the increase in the volume of the chamber, whereupon the particles drop to the bottom of the filter gravimetrically.

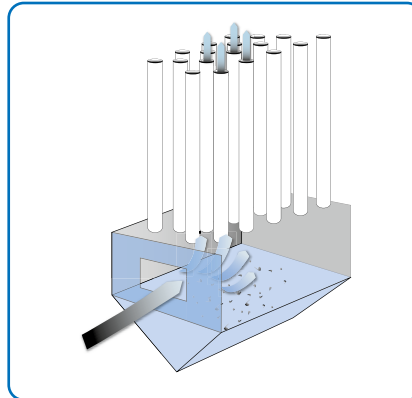

*Air supply chamber*

### Side inlet, settling chamber

The contaminated air is passed into a section where there are no filter bags mounted. The particles are then led down to the bottom of the filter. Consequently, fewer particles will hit the filter bags directly, and thereby, the period between the filter bag cleanings will be longer, which also results in lower energy consumption. Side inlet is suitable for large amounts of material and for materials with hard and sharp surfaces.

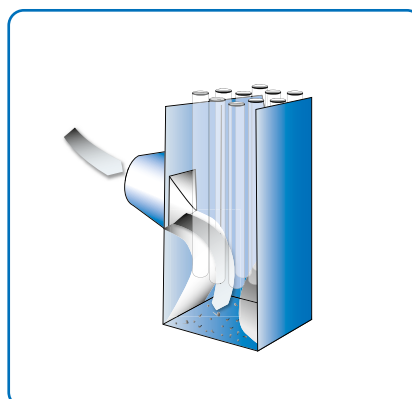

*Side inlet, settling chamber*

### Side inlet, partial downflow

The contaminated air is passed into the filter where it hits a perforated plate. This separates out most of the particles, which bounce off and fall to the filter bottom. Consequently, there are fewer particles in the air which passes through the filter bags, and the regulated air flow means even pressure distribution on the filter surface. The result is longer periods between and less energy for filter bag cleaning.

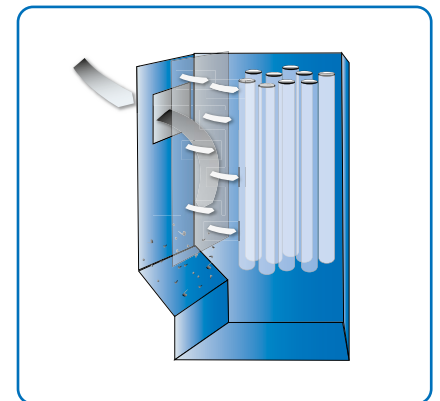

*Partial downflow*

Side inlet is suitable for material with hard and sharp surfaces.

- More filter inlets and very large filters are possible
- Extremely low pressure loss
- Extended service life
- More effective filtering
- Low noise level
- Extended cleaning intervals
- More flexible planning
- Lower energy consumption
- Lower operating costs

## Discharge systems

Filter discharge is adapted and selected according to type and volume of material. See diagram below for discharge systems (according to filter type).

### Other discharge systems

MMBF and older modular filter types have other discharge systems, such as screw conveyor or chain-mounted conveyors. These systems are described under the respective filter types.

Different discharge systems

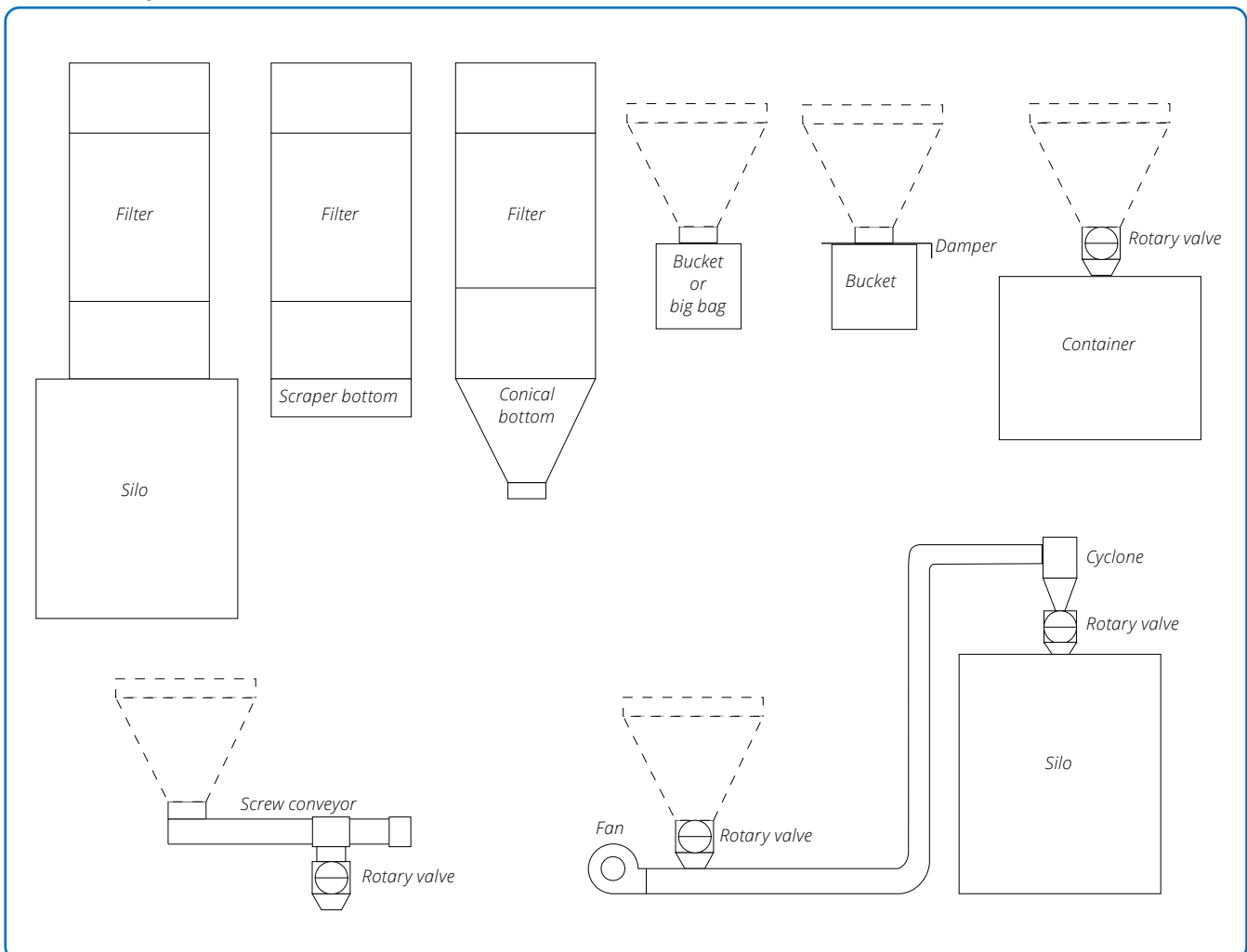

## Cleaning systems

Various systems are used to clean the filter units, depending on filter type.

- PowerPulse® cleaning
- EC cleaning
- Regenerating blower
- Shaking mechanism

### PowerPulse® cleaning

The PowerPulse® cleaning system cleans filter bags using compressed air. The cleaning arm on which the system's jet valves are mounted, moves accurately from bag to bag. One filter bag at a time is cleaned.

The PowerPulse® system gives optimum cleaning with lower energy consumption than any other compressed air-based system. PowerPulse® is available for Blower, SuperBlower, DustStorm® and SuperJet filters. These can all be upgraded with PowerPulse®, mounted on the existing filter top.

The PowerPulse® system's low jet pressure of 1.5–3 bar means very low energy consumption, uniform filter cleaning and minimal wear on the filter medium.

PowerPulse® for BF and DS is supplied with ECOTROL® control system. The SuperJet filter is supplied with ECO-PowerPulse®. Both control systems are CPU-based. The communications protocol works with most PCs and PLCs. The ECOTROL® control system monitors all components in the cleaning system, and faults can be displayed on either the main control panel or the control unit.

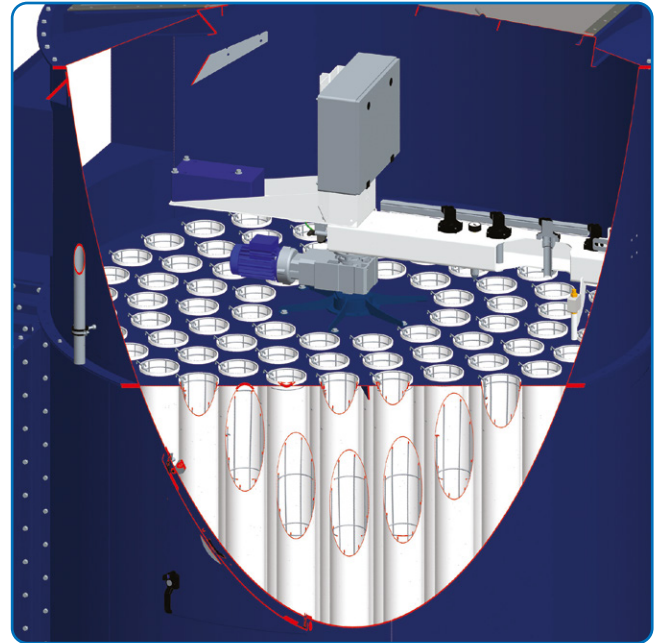

*PowerPulse® cleaning in BF*



*PowerPulse® cleaning in SBF*

## Cleaning systems

### EC cleaning

EC cleaning cleans filter units using compressed air. Several units are cleaned at a time by a single jet valve. The pipes are fitted with specially-designed jet nozzles located precisely above each filter unit. The jet nozzles provide optimal filter unit cleaning.

#### Benefits:

- Manual setting of pulse and pause times
- Can be controlled either by an external pressure valve or PLC control system
- Total cleaning using a predetermined series of discharges
- One or more cycle "final cleaning" for each shut-down to remove residual dust from the filter. "Final cleaning" starts whenever the fan stops.

### Regenerating blower

The regenerating blower is used for cleaning modular filters. One module at a time is regenerated, as there are partition walls between the modules. The regenerating fan cycle is regulated depending on filter load and dust volume. Cleaning is achieved by reversing the air flow and passing it down through the filter bags, causing dust on the inside of the bags to fall down to the bottom section. The regenerating fan is an axial fan designed to generate high pressure during operation and low flow resistance when idle.

### Shaking mechanism

The shaking mechanism only operates during pauses when the filter is not in operation. The mechanism shakes the filter bags, causing dust on the inside of the bags to fall down to the filter bottom.

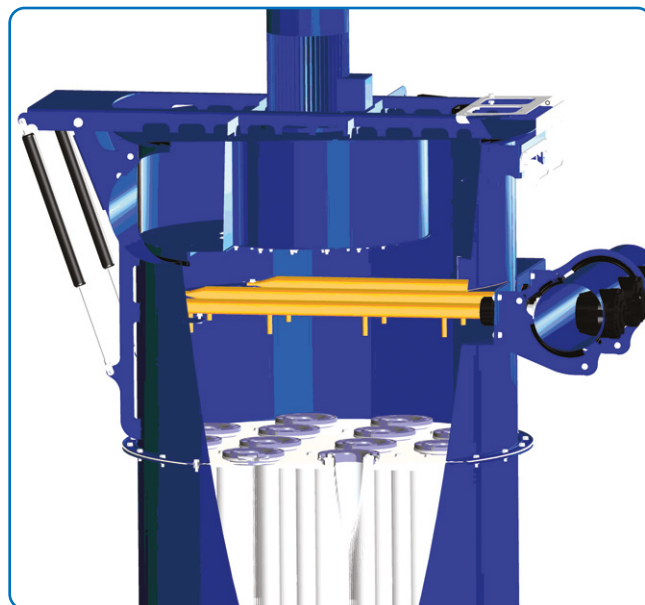

*EC cleaning*



*Regenerating blower*



Dust is often very explosive. The requirements for explosion relief are formulated in the ATEX directive, and are intended to prevent uncontrolled explosive pressure in the event of a dust explosion.

An industrial filter consists of a dust-filled part on the inlet side of the filter bags and a clean air part on the output side. Dust explosions occur in the dust-filled chamber and according to the ATEX directive must either be suppressed or released under control into the surrounding environment. Normal explosion membranes are used for the latter.

According to applicable norm DS/EN 14491:2012, explosion membranes are to be placed in the dust-filled chamber, unless sufficient explosion relief can be demonstrated. The majority of all industrial filters on the market have the dust-filled chamber at the bottom of the filter. Placing them there means a dust explosion will usually occur as shown in the illustration. By opening the explosion membrane, the explosion pressure is released horizontally. Flames and burning dust particles will be thrown out of the dust-filled chamber and non-ignited dust thrown out can be ignited outside the chamber in a secondary explosion.

The risk of damage to buildings and injury to personnel therefore makes locating the filter in this manner a problem.

**VFV® explosion relief venting**

JKF has increased safety by venting an explosion vertically into the clean air chamber, as shown in illustration 2. Explosion membranes are placed in the top of the filter. This ensures that explosion dust is kept in the filter bags and only the shock wave has to be vented to the surrounding environment. This eliminates the risk of a secondary explosion, and anyone near the filter at the time will not be exposed to the shock wave.

**Optional extras/accessories**

Explosion sensors are available for monitoring an installation. The sensor detects if an explosion membrane opens and sends a signal to shut-off other components – e.g. fans.

Explosion sensors can easily be retro-fitted to existing plants.

Explosion conduits are available for filters located outside production facilities. If an explosion occurs, it will be channelled outside via the conduit.

VFV® explosion relief venting has been explosion tested and approved by the German FSA test institute on several of our filters.



1. Explosion relief venting in the filter body



2. VFV® explosion relief venting

# ATEX explosion relief

Explosion calculation according to DS/EN 14491:2012.  
Calculations performed using WinVent 4.0 E software.

The membranes have an opening pressure of:  $P_{stat} = 10$  [kPa]

Calculations apply to wood dust at 20°C.

Apart from testing at FSA, JKF uses FEM calculation to determine pressure shock-resistance.

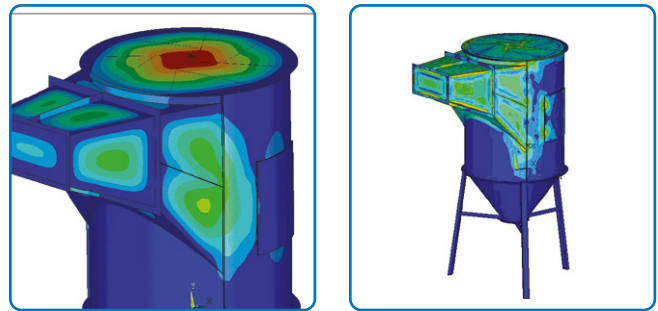
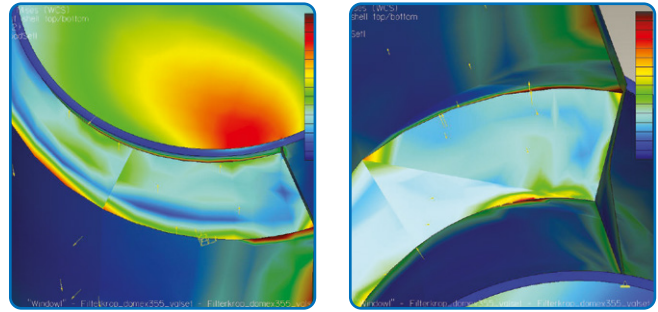

**EC-Certificate**  
No. EX9 07 05 48836 007

**Holder of Certificate:** JKF Industri A/S  
Rosvangens 5, Åls  
8660 Haldens  
DENMARK

**Name of Object:** Nonelectrical devices and components group II Filters

**Model(s):** H 2 D c T100 °C  
SBF x - h - S - I (scraper)  
SBF x - h - K - I (scraper conveyor)  
x: number of bags 120 - 840 (increment 20)  
I: Filterbag length 5,0 - 5,0 (increment 0,5)  
I: number of inlets and type (A,B,C)

**Description of Object:** One set of technical documentation in paperform

**Test report no.:** 71323108

**Date:** 2007-06-25

This EC-Certificate is issued according to Article 8(1) (i) of Council Directive 94/9/EC for equipment and protective systems intended for use in potentially explosive atmospheres (ATEX). It confirms the receipt and storage of the file for the latest product by TÜV SÜD Product Service GmbH. It was not verified whether the documentation is correct and complete. See also notes overleaf.

TÜV SÜD Product Service GmbH • Zertifikatsstelle • Riferenzstrasse 65 • 80339 München • Germany

**EC-Certificate**  
No. EX9 09 10 48836 011

**Holder of Certificate:** JKF Industri A/S  
Rosvangens 5, Åls  
8660 Haldens  
DENMARK

**Name of Object:** Nonelectrical devices and components group II Blowerfilter

**Model(s):** BF-uCT-ET-EX y-h-d  
BF-uCT-ET-EX 1-h-d (tangential inlet below filterbags)  
BF-uCT-ET-EX y-PP-F-d (vertical flameless venting)  
BF-uCT-ET-T-PP-F-d  
x: 38,60,34,50 Number of filterbags  
C1: Closed line  
ET: External compressed air  
y: SIK - Scraper bottom / Cone  
h: 1,6-6,0 Length of Blowerbag (Increment 0,6)  
d: RL - Direction of inlet

**Description of Object:** 1 Set of technical documentation of product  
This certificate is valid until 2018-07-08

**Test report no.:** 71369742

**Date:** 2009-10-26

This EC-Certificate is issued according to Article 8(1) (i) of Council Directive 94/9/EC for equipment and protective systems intended for use in potentially explosive atmospheres (ATEX). It confirms the receipt and storage of the file for the latest product by TÜV SÜD Product Service GmbH. It was not verified whether the documentation is correct and complete. See also notes overleaf.

TÜV SÜD Product Service GmbH • Zertifikatsstelle • Riferenzstrasse 65 • 80339 München • Germany

**EC - CERTIFICATE**

**Equipment:** Rotary Valve  
**Manufacturer:** Model RL-S and Model B-S

**Name of Object:** H 2 D Tn

**Model(s):** H 2 D Tn

**Description of Object:** The marking of the equipment or protective system shall include the following:  
Ex H 2 D Tn

**Test report no.:** TI 2007-01-0041 A

**Date:** 2007-05-22

This EC-Certificate is issued according to Annex VIII clause 2 of Council Directive 94/9/EC for equipment and protective systems intended for use in potentially explosive atmospheres (ATEX). The certificate confirms the receipt and storage of the technical documentation received from the certificate holder. It was not verified whether the documentation is correct and complete. See also notes overleaf.

DANAK  
Højbjergvej 10  
DK-4500 Haldens  
Denmark

TÜV SÜD Product Service GmbH • Zertifikatsstelle • Riferenzstrasse 65 • 80339 München • Germany

**EC-Certificate**  
No. EX9 08 03 48836 009

**Holder of Certificate:** JKF Industri A/S  
Rosvangens 5, Åls  
8660 Haldens  
DENMARK

**Name of Object:** Nonelectrical devices and components group II Dust-Storm-Filter

**Model(s):** DS-7 EC  
DS-12 K & S ET EX  
DS-20 K & S ET EX  
DS-30 K & S ET EX  
DS-34 K & S ET EX  
DS-44 K & S ET EX  
DS-12 EC

**Description of Object:** One set of technical documentation in paperform.

**Test report no.:** 70688997-7134523

**Date:** 2008-03-12

This EC-Certificate is issued according to Article 8(1) (i) of Council Directive 94/9/EC for equipment and protective systems intended for use in potentially explosive atmospheres (ATEX). It confirms the receipt and storage of the file for the latest product by TÜV SÜD Product Service GmbH. It was not verified whether the documentation is correct and complete. See also notes overleaf.

TÜV SÜD Product Service GmbH • Zertifikatsstelle • Riferenzstrasse 65 • 80339 München • Germany

**ATEX-MÆRKNING**

Parameter	Value	Unit
Explosion pressure	10	kPa
Explosion temperature	20	°C
Explosion velocity	10	m/s
Explosion pressure	10	kPa
Explosion temperature	20	°C
Explosion velocity	10	m/s

**JKF Industri**  
CLEAN AIR INNOVATION SINCE 1957



## Ladders and gangways

Ladder and gangway solutions for JKF filters are designed according to ISO/EN/DIN 14122.

JKF has a wide range of different ladders and gangways, so that a solution can be adapted to a given installation using standard parts.

### Ladder with gangway SBF

The ladder is mounted close to the filter body with sideways exit onto the gangway. Additional gangways can be attached along the length of the ladder. This provides access to several gangways via a single ladder. Single or double gangways are available. The width of a single gangway corresponds to that of the door section.

### Ladder with gangway, side-mounted SBF

The ladder is at right angles to the filter. Access to the gangway is via the ladder's side rails.

Supplied with single and double gangway.

### Ladder with gangway, front-mounted on SBF and BF

The ladder is offset from the filter, making room for pipes run between ladder and filter. Access to the gangway is via the ladder's side rails. Supplied with single gangway only.

### Benefits

A modular ladder system means easier adaptation to and expansion of a given installation.

Fewer components simplify installation and overview.

Self-closing hatches on the gangway prevent falls.

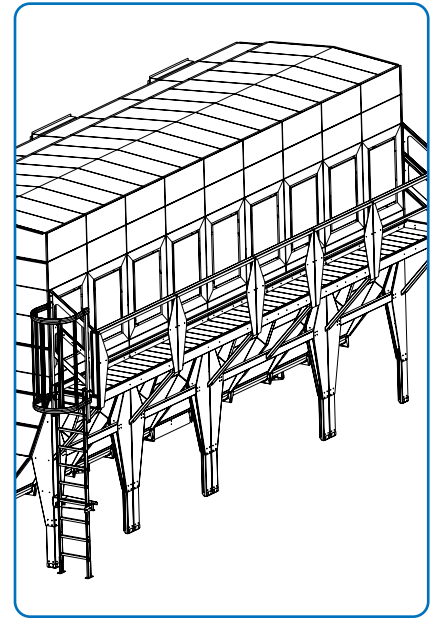

Ladder with gangway SBF



Ladder with gangway, side-mounted SBF



Ladder with gangway, front-mounted SBF



Ladder with gangway DS



Ladder with extra double gangway BF



Ladder with gangway, front-mounted BF

## Filter selection

Extraction from industrial premises is usually intended to:

- remove undesirable contaminants such as particles, dust, smells, smoke or gases from process and/or working zones before they spread.
- create balance between the volume flow blown-in and extracted

Extraction in an industrial ventilation scenario is often in the form of point extraction located as close to the source of pollution as possible, and designed for optimal efficiency. Room extraction is also recommended.

### Dust separators

Common for many industrial processes is that dust is generated. Pollution sources are multiple, and just about all particle sizes are represented. Air purification can therefore be divided into groups:

- dynamic separators in the form of cyclones and separators
- bag filters, possibly combined with cyclones
- bag filters with integrated tangential inlet

Separation of particles by filtering depends primarily on physical and mechanical effects. Common to all purification methods is that separation efficiency depends on particle size, where the degree of separation rises with rising particle size.

In health terms, particles – of less than  $1\mu\text{m}$  – are by far the most dangerous, as they can reach the respiratory passages via inhalation.

### Filters

Filters for material separation are intended to purify exhaust air with strong dust concentrations. Air is purified in the filters by passing through a filter medium, and the degree of separation depends primarily on the density of the medium, particle size and load.

Furthermore, electrostatic forces can help trap and retain particles on the fibres to a certain degree. Filter media are made of synthetic fibre, glass or natural fibres, and come in different thicknesses and degrees of density. JKF uses only approved filter media which are certified.

It is important that air resistance in the filter is kept as low as possible, so that the air flow is not reduced, and energy consumption is kept as low as possible.

### Dynamic separators

Dynamic separators are used for the separation of larger particles. As such, they can reduce the amount of dust in the air purified by the filter, ensuring more efficient operation and lower energy consumption. The separator's configuration ensures low pressure loss and material separation with minimal discharge of air.

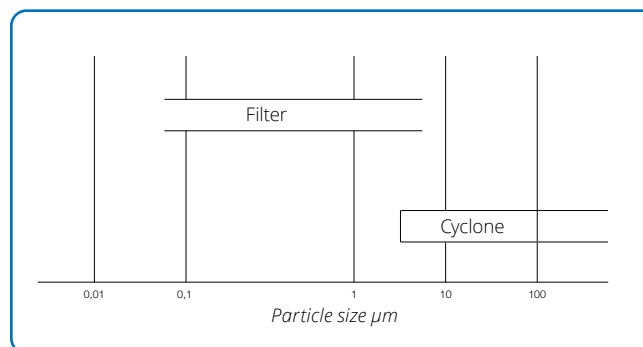

Cyclones consist of a simple cone-shaped and cylindrical chamber, which reaches a point at the bottom. The contaminated air is passed tangentially in to the top of the cyclone to form a screw-shaped cyclone in the chamber. Centrifugal force throws the particles outwards towards the chamber walls, and they fall to the bottom of the cyclone into a collection box before being passed into a sluice. The purified air is passed through a centrally located discharge at the top of the chamber.

The cyclone principle is mainly suited to the separation of coarse particles. The degree of separation is typically 70-80% for particles around 5 mm in diameter. The degree of separation in a cyclone increases with rising air velocity inlet and narrower diameter.

Cyclones can also be used as separators in combination with another form of air purification.

Mechanical separation of particles takes place in a separator. Dust-filled air is passed into a chamber, where a rotor runs against a perforated plate. The rotor directs larger particles (over 3 mm) towards a discharge in the bottom of the chamber, whilst the air and smaller particles diffuse through the perforated plate and on to a filter.

Dynamic separation means that the separator can be more compact than a settling chamber.

### Filtration degrees

JKF's filters are intended for the purification of exhaust air with heavy dust concentrations, and can be in the form of cartridge or bag filters. Air is purified in the filters by passing through a textile filter medium, and the degree of separation depends primarily on the density of the medium. Separation efficiency is up to 99.98%.

## Filter selection

Filter type		SBF	BF	BF-EC	BF-ET	DS	DS7/12 EC	Jetline K	SJF	MMBF	Modular filter	Intake filter	Point filter
<b>ATEX approved</b>		x		x	x	x	x	x	x	x			
<b>Overpressure</b>		x	x	x	x	x	x	x	x	x	x		
<b>Underpressure</b>		x	x	x	x	x	x	x	x	x		x	x
<b>Inlet</b>	<b>Tangential inlet</b>	x	x	x	x	x	x						
	<b>Air supply chamber</b>									x	x	x	
	<b>Side inlet, settling chamber</b>	x									x		
	<b>Side inlet, partial downflow</b>					x		x	x				
<b>Discharge</b>	<b>Conical bottom</b>		x	x	x	x	x	x		x	x		
	<b>Screw</b>									x	x		
	<b>Rotary valve</b>	x	x	x	x	x	x		x	x	x		
	<b>Scraper bottom</b>	x	x	x *)	x	x			x				
	<b>Bucket</b>	x	x	x	x	x	x	x		x	x		
	<b>Bag</b>									x	x		
<b>Filter cleaning</b>	<b>PowerPulse® cleaning</b>	x			x	x			x				
	<b>Regenerating blower</b>									x	x		
	<b>EC cleaning</b>			x			x						
	<b>Shaking mechanism</b>										x		
	<b>Triopticlean</b>							x					

List of JKF filter types  
 \*) Only BF-20 EC

## SuperBlower filter

The SuperBlower filter is an under- and over-pressure filter designed to run in constant operation.

Constructed as a self-supporting sheet metal construction in high tensile steel modules. Process air is passed into a filter chamber, where the larger particles settle to the bottom of the filter, from where the air is passed through filter bags which retain the residual particles.

The modular SuperBlower filter is a flexible design which can be adapted to any given task in terms of capacity by dimensioning the filter height and the number of filterbags.

### Surface

Powder coated to corrosion class C3 cf. ISO 12944.

### Inlet

The SuperBlower filter is available with 180° tangential inlet, standard 706 x 1806 mm or large 1006 x 2106 mm. Inlets can be fitted at both ends of the filter.

### Cleaning system

The filter is delivered with PowerPulse®.

### Discharge system

Scraper bottom with outlet for rotary valve, screw, bucket or container.

### ATEX

SuperBlower filter with PowerPulse® cleaning and external compressed air is ATEX approved and fitted with JKF's specially developed VFV® explosion relief venting (vertical explosion relief venting through the filter top).

### Operating range

Pressure: +/- 5000 Pa  
Filter area: 221-1295 m<sup>2</sup>  
Max. operating temperature: 40°C  
Min. operating temperature: -10°C

### Connection

Gear motor cleaning carriage:  
0.18 kW, 20.0 min<sup>-1</sup>, 3 x 230 V, 50 Hz, 0.9 A

### Gear motor scraper bottom:

2 x 0.75 kW, 17.5 min<sup>-1</sup>, 3 x 400 V, 50 Hz, 2 x 2.2 A

### Inductive sensor, scraper bottom:

24 VDC

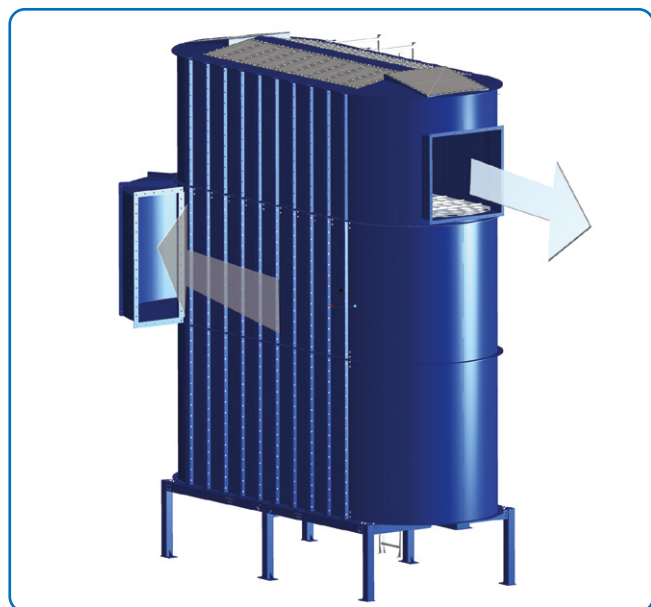

*SBF filter with scraper bottom and tangential inlet.  
Shown here with VFV® explosion relief venting in filter top.*

## SuperBlower filter

### PowerPulse® filter control system:

0.6 kW, 1 x 230 V, 50 Hz, 1.9 A

### External compressed air - PowerPulse®:

5 bar, min. 350 NI/min.

Air quality according to ISO 8573-1: 2010 [5:3:4]

External connection: 1/4" internal thread.

### Noise

Noise level during cleaning measured 5 m from the filter in ground level:

External compressed air PowerPulse®: 69.8 dBA

Internal compressor PowerPulse®: 74.6 dBA

### Accessories

#### Ladder/gangway:

Ladder/gangway designed according to ISO/EN/DIN 14122.3/4 and available in several configurations. See page 11.

Ladder with gangway, front-mounted

Ladder with gangway, side-mounted

Ladder with double gangway, front-mounted

Ladder with double gangway, side-mounted

Monitoring apparatus for explosion membrane

#### Door contacts:

2.3 (close-before-switch-contact) in accordance with EN50047, IP67 NC contact.



*SBF filter with scraper bottom and side inlet.  
Shown here with VFV® explosion relief venting in filter top.  
With ladder and platform mounted.*

# SuperBlower filter

## Type designations

Filters are type-designated using a combination of letters and numbers separated by hyphens and spaces.

Designation SBF-202 5 - 0 - 1C (8) thus describes a Super-Blower filter with 202 filter bags, 5 m filter bags and 1 side inlets.

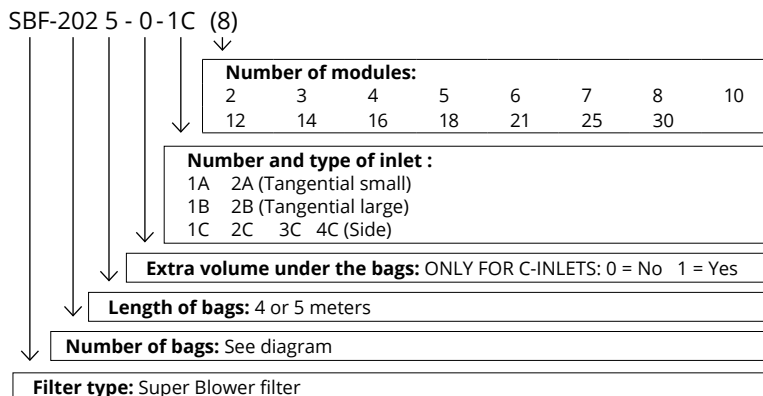

INLET A						INLET B						L1	L2	No. of legs	H
1			2			1			2						
Bags	Area	Description 2	Bags	Area	Description 2	Bags	Area	Description 2	Bags	Area	Description 2				
122	221	SBF-122 4-0-1A (2)				122	221	SBF-122 4-0-1B (2)				840	2113	4	7471
142	258	SBF-142 4-0-1A (3)				142	258	SBF-142 4-0-1B (3)				1260	2533	4	7471
142	316	SBF-142 5-0-1A (3)				142	316	SBF-142 5-0-1B (3)				1260	2533	4	8471
162	294	SBF-162 4-0-1A (4)				162	294	SBF-162 4-0-1B (4)				1680	2953	4	7471
162	361	SBF-162 5-0-1A (4)				162	361	SBF-162 5-0-1B (4)				1680	2953	4	8471
182	330	SBF-182 4-0-1A (5)	182	330	SBF-182 4-0-2A (5)	182	330	SBF-182 4-0-1B (5)				2100	3373	4	7471
182	405	SBF-182 5-0-1A (5)	182	405	SBF-182 5-0-2A (5)	182	405	SBF-182 5-0-1B (5)				2100	3373	4	8471
			202	450	SBF-202 5-0-2A (6)	202	450	SBF-202 5-0-1B (6)				2520	3793	6	8471
			222	494	SBF-222 5-0-2A (7)	222	494	SBF-222 5-0-1B (7)	222	494	SBF-222 5-0-2B (7)	2940	4213	6	8471
			242	539	SBF-242 5-0-2A (8)	242	539	SBF-242 5-0-1B (8)	242	539	SBF-242 5-0-2B (8)	3360	4633	6	8471
									282	628	SBF-282 5-0-2B (10)	4200	5473	8	8471
									322	717	SBF-322 5-0-2B (12)	5040	6313	8	8471
									362	806	SBF-362 5-0-2B (14)	5880	7153	10	8471
									402	895	SBF-402 5-0-2B (16)	6720	7993	10	8471
									442	984	SBF-442 5-0-2B (18)	7560	8833	10	8471
									502	1117	SBF-502 5-0-2B (21)	8820	10093	12	8471
									582	1295	SBF-582 5-0-2B (25)	10500	11773	12	8471

INLET C															
1			2			3			4			L1	L2	No. of legs	H
Bags	Area	Description 2	Bags	Area	Description 2	Bags	Area	Description 2	Bags	Area	Description 2				
122	221	SBF-122 4-0-1C (4)										1680	2953	4	7471
122	221	SBF-122 4-1-1C (4)										1680	2953	4	8471
122	271	SBF-122 5-0-1C (4)										1680	2953	4	8471
122	271	SBF-122 5-1-1C (4)										1680	2953	4	9471
142	258	SBF-142 4-0-1C (5)										2100	3373	4	7471
142	258	SBF-142 4-1-1C (5)										2100	3373	4	8471
142	316	SBF-142 5-0-1C (5)										2100	3373	4	8471
142	316	SBF-142 5-1-1C (5)										2100	3373	4	9471
162	361	SBF-162 5-0-1C (6)										2520	3793	6	8471
162	361	SBF-162 5-1-1C (6)										2520	3793	6	9471
182	405	SBF-182 5-0-1C (7)										2940	4213	6	8471
182	405	SBF-182 5-1-1C (7)										2940	4213	6	9471
202	450	SBF-202 5-0-1C (8)	162	361	SBF-162 5-0-2C (8)							3360	4633	6	8471
202	450	SBF-202 5-1-1C (8)	162	361	SBF-162 5-1-2C (8)							3360	4633	6	9471
			202	450	SBF-202 5-0-2C (10)							4200	5473	8	8471
			202	450	SBF-202 5-1-2C (10)							4200	5473	8	9471
			242	539	SBF-242 5-0-2C (12)							5040	6313	8	8471
			242	539	SBF-242 5-1-2C (12)							5040	6313	8	9471
			282	628	SBF-282 5-0-2C (14)							5880	7153	10	8471
			282	628	SBF-282 5-1-2C (14)							5880	7153	10	9471
			322	717	SBF-322 5-0-2C (16)							6720	7993	10	8471
			322	717	SBF-322 5-1-2C (16)							6720	7993	10	9471
			362	806	SBF-362 5-0-2C (18)	322	717	SBF-322 5-0-3C (18)				7560	8833	10	8471
			362	806	SBF-362 5-1-2C (18)	322	717	SBF-322 5-1-3C (18)				7560	8833	10	9471
			422	939	SBF-422 5-0-2C (21)	382	850	SBF-382 5-0-3C (21)	342	761	SBF-342 5-0-4C (21)	8820	10093	12	8471
			422	939	SBF-422 5-1-2C (21)	382	850	SBF-382 5-1-3C (21)	342	761	SBF-342 5-1-4C (21)	8820	10093	12	9471
						462	1028	SBF-462 5-0-3C (25)	422	939	SBF-422 5-0-4C (25)	10500	11773	12	8471
						462	1028	SBF-462 5-1-3C (25)	422	939	SBF-422 5-1-4C (25)	10500	11773	12	9471
									522	1162	SBF-522 5-0-4C (30)	12600	13873	14	8471
									522	1162	SBF-522 5-1-4C (30)	12600	13873	14	9471



## SuperBlower filter

### INLET A

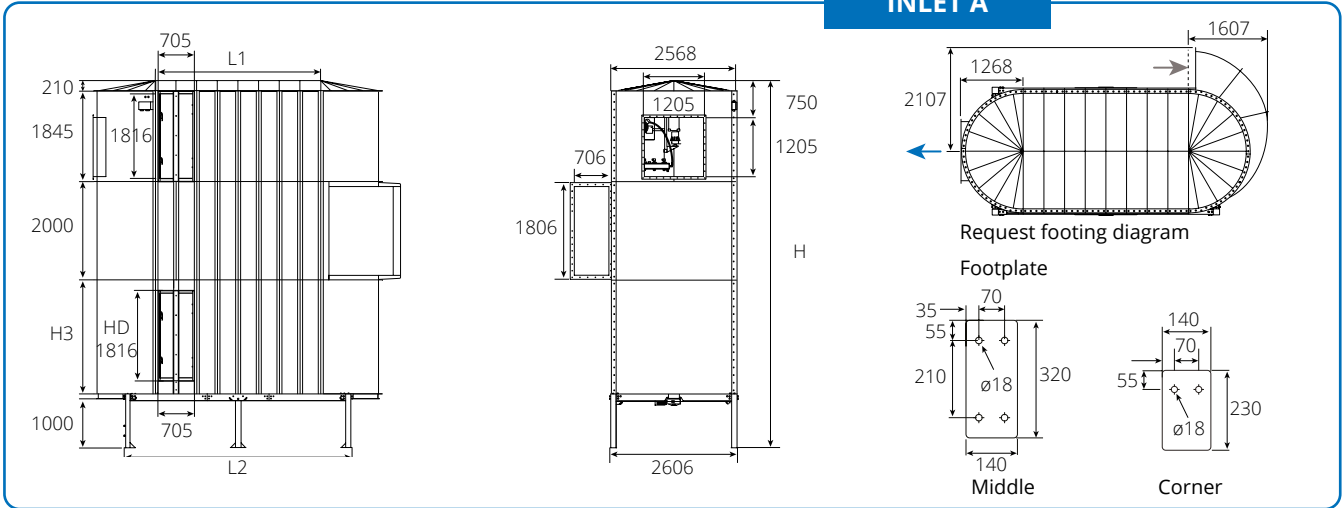

### INLET B

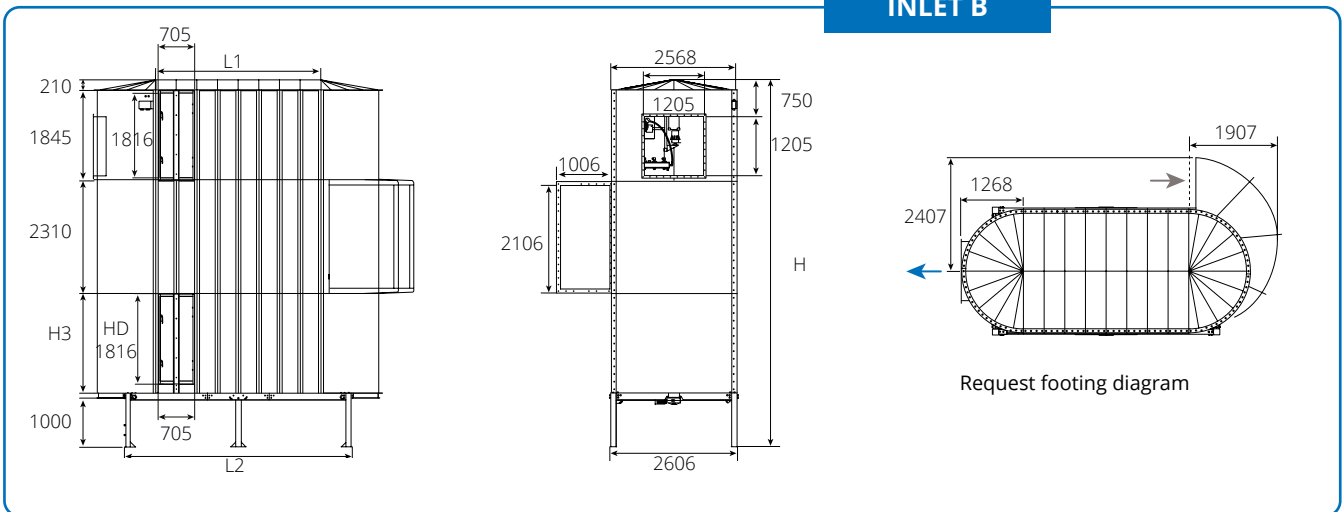

### INLET C

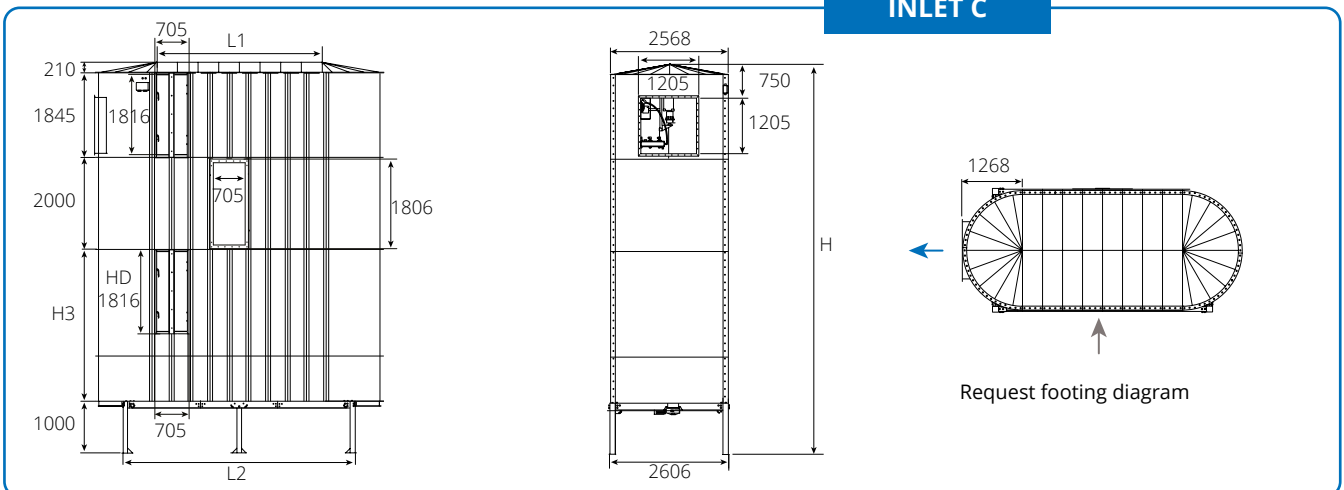

## Blower and EC-filters

The blower and EC-filter is an under- and over-pressure filter, designed for continuous operation. Constructed as a self-supporting sheet metal construction. The round design ensures great strength combined with low weight.

### Surface

Powder coated to corrosion class C3 cf. ISO 12944.

### Inlet

The Blower and Jet filters are fitted with 180° tangential inlets to ensure effective sorting of heavy materials before the process air passes through the filter medium.

BF-34, 36, 55, 60 and 90-filters are also available with total separators. Standard height is 1000 mm, with the inlet at 90°C. This type of inlet is used in plants in which the process air contains heavy and sharp articles to prevent them coming into contact with the filter medium.

### Cleaning system

BF-36, 60, 90 ET filters are supplied with PowerPulse®. BF-8, 12, 20, 34, 55 filters are supplied with EC-cleaning.

### Discharge system

Conical or scraper bottoms are available for the discharge system, but silo filter is also available.

### ATEX

Choose between side venting or JKF's specially developed VFV® explosion relief venting, which vents explosion pressure vertically through the filter top.

### Operating range

Pressure:	+/- 5000 Pa
Filter area:	7.7-200 m <sup>2</sup>
Max. operating temperature:	70°C
Min. operating temperature:	-20°C (available for: -40 °C)

### Connection

Gear motor Blower-cleaning:

**Connection EC filter control system BF-8, 12, 20, 34, 55:**

0,25 kW, 1 x 230 V, 50 Hz, 0,1 A

**Gear motor PowerPulse® cleaning system:**

0.12 kW, 15.6 min<sup>-1</sup>, 3 x 230 V, 50 Hz, 0.7 A

**Gear motor scraper bottom:**

Type 20: 0.25 kW, 15.7 min<sup>-1</sup>, 3 x 400 V, 50 Hz, 1.1 A

Type 34, 36: 0.55 kW, 11.0 min<sup>-1</sup>, 3 x 400 V, 50 Hz, 1.7 A

Type 55, 60 and 90: 0.75 kW, 11.0 min<sup>-1</sup>, 3 x 400 V, 50 Hz, 2.2 A

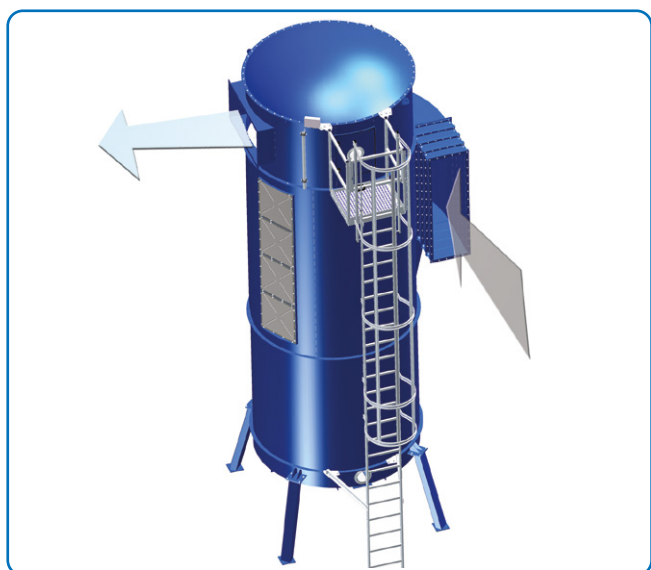

BF-filter with scraper bottom and tangential inlet.  
Shown with explosion relief venting in side.  
With ladder and platform mounted.



BF-filter with scraper bottom and tangential inlet.  
Shown with VFV® explosion relief venting in the filter top.  
Fitted with ladder and platform.

## Blower- and EC-filters

### Inductive sensor, scraper bottom:

24 VDC

### PowerPulse® ECOTROL® filter control system, BF-CT-ET:

0.6 kW, 1 x 230 V, 50 Hz, 1.9 A

### External compressed air - PowerPulse®:

5 bar, min. 350 NI/min.

Air quality according to ISO 8573-1: 2010 [5:3:4]

External connection: 1/4" internal thread.

### Noise

Noise level during cleaning measured 5 m from ground level:

EC: 70.0 dBA

PowerPulse®: 70.4 dBA

### Accessories

#### Ladder/gangway:

Ladder/gangway designed according to ISO/EN/DIN 14122.3/4 and available in several configurations.

- Ladder with gangway, front-mounted
- ladder with double gangway, front-mounted
- monitoring equipment for explosion membrane

#### Door contacts:

2.3 (close-before-switch-contact) in accordance with EN50047, IP67 NC contact.

### Type designations

Filters are type-designated using a combination of letters and numbers separated by hyphens and spaces. Designation BF-36CT-ET S VFV 3.0-R therefore describes a Blower filter with 36 filter bags, PowerPulse® cleaning system with ET, scraper bottom, vertical explosion relief venting, 3 m filter bag and right inlet.

### BF-36CT-ET EX T S VFV 3,0-R

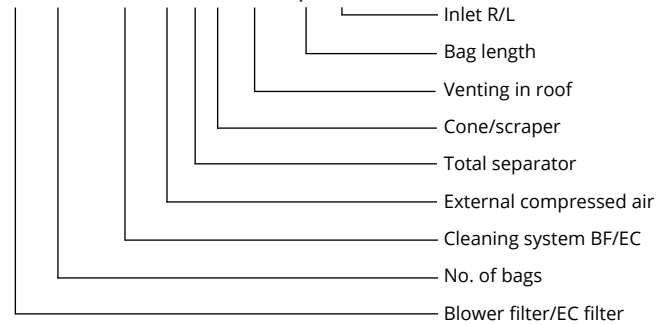

Please state location of inlet and discharge including angle degrees when ordering. The explosion membrane for side venting is always located 150SDgr from the inlet

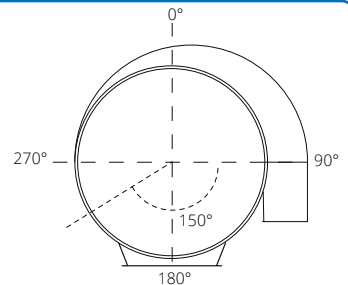

Blower-filter with scraper bottom and tangential inlet. Cross-section shows the PowerPulse® cleaning system.

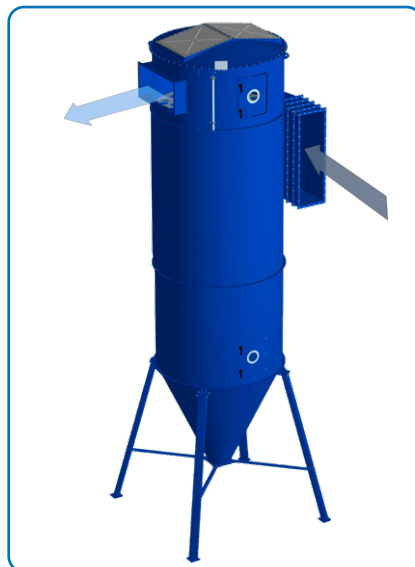

Blower-filter with conical bottom and tangential inlet.



Blower-filter with conical bottom and total separator.

## Blower filters

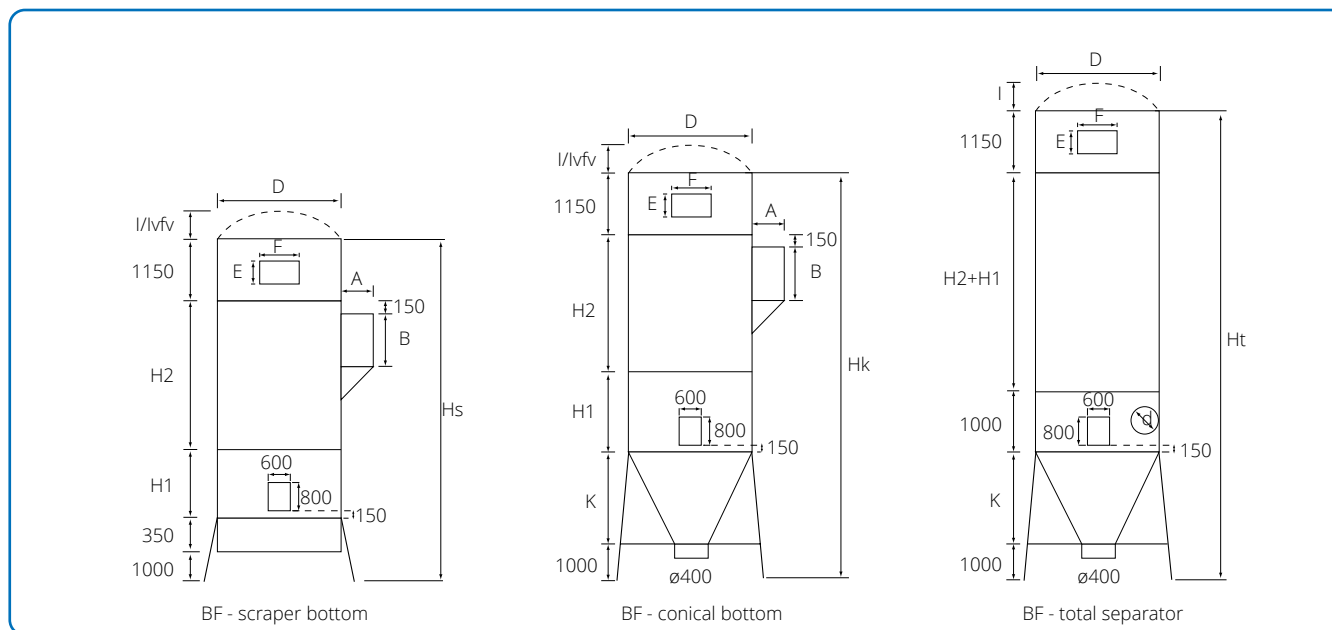

	Filter area m <sup>2</sup>	D mm	Hs mm	H1 mm	H2 mm	Hk mm	K mm	Ht mm	d mm	l mm
<b>BF-36 - 2,0</b>	34,3	1500	4503	-	2000	5338	1185	6338	400	210
<b>BF-36 - 3,0</b>	51,3	1500	5503	1000	2000	6338	1185	7338	2 x 400	210
<b>BF-36 - 4,0</b>	65,4	1500	6503	2000	2000	7338	1185	8338	2 x 400	210
<b>BF-36 - 5,0</b>	80,0	1500	7503	3000	2000	8338	1185	9338	2 x 400	210
<b>BF-60 - 2,0</b>	57,2	1900	4507	-	2000	5767	1610	6767	600	260
<b>BF-60 - 3,0</b>	85,5	1900	5507	1000	2000	6767	1610	7767	600	260
<b>BF-60 - 4,0</b>	108,9	1900	6507	1500	2500	7767	1610	8767	600	260
<b>BF-60 - 5,0</b>	133,4	1900	7507	2500	2500	8767	1610	9767	600	260
<b>BF-90 - 3,0</b>	128,2	2350	5500	-	3000	7240	2084	8240	800	350
<b>BF-90 - 4,0</b>	163,4	2350	6500	1000	3000	8240	2084	9240	800	350
<b>BF-90 - 5,0</b>	200,1	2350	7500	2000	3000	9240	2084	10240	800	350

BF-36-60, 90 has one filter door in the top section and one in the filter body (600×800 mm).

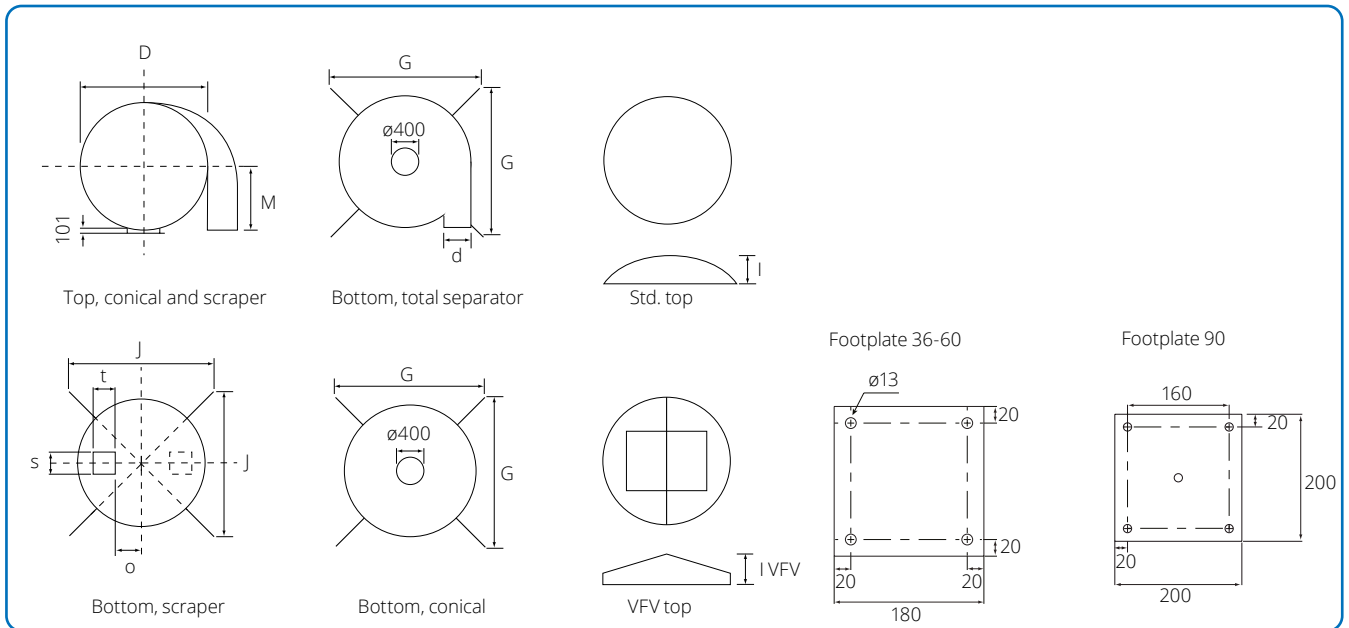

I VFV mm	A×B mm	E×F mm	G mm	J mm	O mm	S×T mm	M mm	Weight with conical kg	Weight with bottomscraper kg	Weight with bottom total separator kg
290	400×800	600×600	1878	1672	455	220×500	400	966	982	975
290	400×800	600×600	1878	1672	455	220×500	400	1086	1101	1086
290	400×800	600×600	1878	1672	455	220×500	400	1181	1123	1192
290	400×800	600×600	1878	1672	455	220×500	400	1292	1308	1305
360	500×900	600×800	2375	1974	655	220×500	600	1455	1441	1360
360	500×900	600×800	2375	1974	655	220×500	600	1620	1607	1663
360	500×900	600×800	2375	1974	655	220×500	600	1806	1792	1850
360	500×900	600×800	2375	1974	655	220×500	600	1971	1957	2005
290	500×1750	600×1200	2875	2292	880	220×500	800	2224	2137	2284
290	500×1750	600×1200	2875	2292	880	220×500	800	2485	2398	2549
290	500×1750	600×1200	2875	2292	880	220×500	800	2740	2653	2765

## EC filters

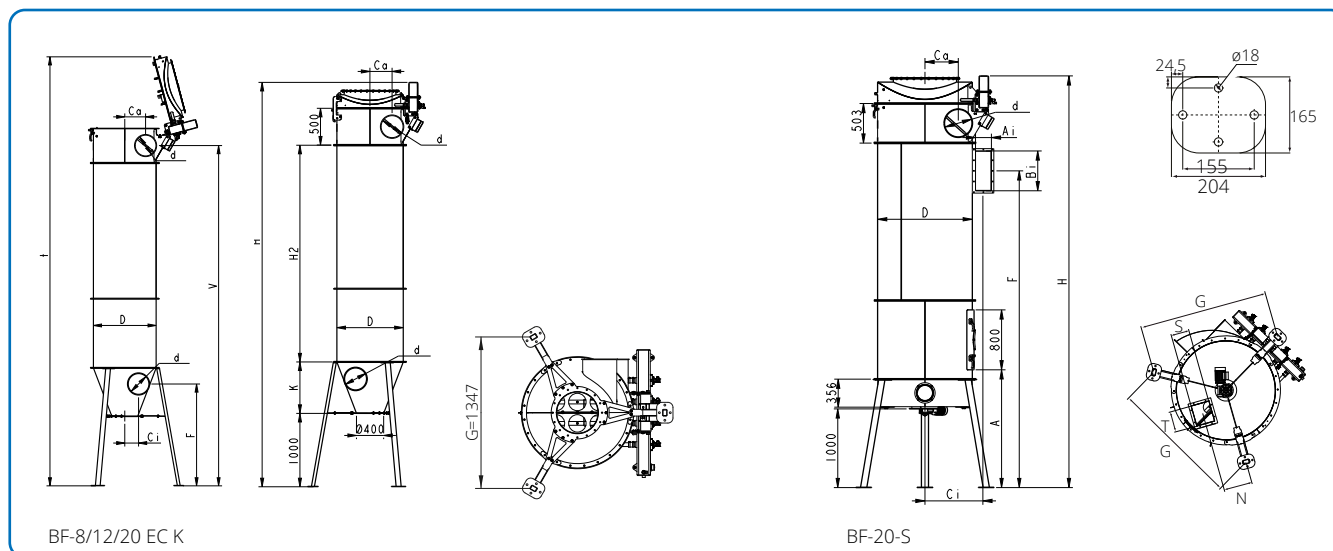

Type	Filter area m <sup>2</sup>	Ai x Bi mm	H mm	t mm	H2 mm	F mm	V mm	Ci mm	Ca mm
BF-8-2,0-KT	7,7		4302*	5025	2000	1506	3905	202	263
BF-12-2,0-KT	11,5		4508*	5167	2000	1469	3905	199	300
BF-12-3,0-KT	17,2		5508*	6167	3000	1469	4905	199	300
BF-20-2,0-KT	19,2		4956*	5933	2000	1850	4353	424	424
BF-20-3,0-KT	28,6		5956*	6933	3000	1850	5353	424	424
BF-20-2,0-K	19,2	200x500	4456*	5433	2000	3247	3853	424	424
BF-20-3,0-K	28,6	200x500	5456*	6433	3000	4247	4853	424	424
BF-20-2,0-S	19,2	200x500	4234*	5212	2000	3025	3631	743	424
BF-20-3,0-S	28,6	200x500	5234*	6212	3000	4025	4631	743	424
BF-34-2,0-K	32,4	400x800	5603		2000	3732	4763	965	
BF-34-3,0-K	48,5	400x800	6603		3000	4632	5763	965	
BF-34-4,0-K	61,8	400x800	7603		4000	5632	6763	1015	
BF-34-2,0-S	32,4	400x800	4762		2000	2897	3928	965	
BF-34-3,0-S	48,5	400x800	5762		3000	3797	4928	965	
BF-34-4,0-S	61,8	400x800	6762		4000	4797	5928	1015	
BF-55-2,0-K	52,4	500x900	6081		2000	4105	5188	1216	
BF-55-3,0-K	78,4	500x900	7081		3000	5105	6188	1216	
BF-55-4,0-K	99,8	500x900	8081		4000	6005	7188	1263	
BF-55-2,0-S	52,4	500x900	4821		2000	2845	3928	1215	
BF-55-3,0-S	78,4	500x900	5821		3000	3845	4928	1215	
BF-55-4,0-S	99,8	500x900	6821		4000	4745	5928	1263	

For side relief below the filter bags, H is increased by 1000 mm.

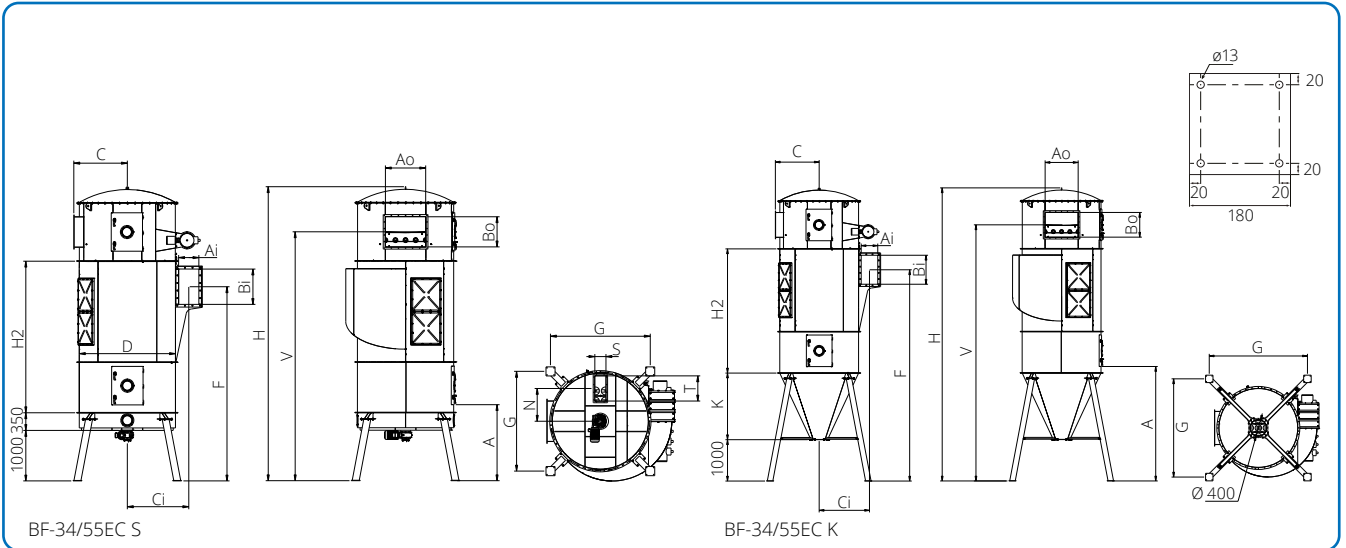

BF-34/55EC S

BF-34/55EC K

C mm	d mm	Ao x Bo mm	D mm	K mm	A mm	N mm	S x T mm	G mm	Weight incl. bags kg
397	225		750	700				1213	280
476	300		900	700				1347	375
476	300		900	700				1347	443
607	350		1200	600				1486	542
607	350		1200	600				1486	628
607	350		1200	600				1486	515
607	350		1200	600				1486	601
607	350		1200		1467	341	220x250	1558	575
607	350		1200		1497	341	220x250	1558	662
858		600x600	1500	1185	2341			1878	1058
858		600x600	1500	1185	2341			1878	1178
858		600x600	1500	1185	2341			1878	1263
858		600x600	1500		1506	450	220x500	1672	1074
858		600x600	1500		1506	450	220x500	1672	1193
858		600x600	1500		1506	450	220x500	1672	1205
1060		800x600	1900	1610	2766			2375	1560
1060		800x600	1900	1610	2766			2375	1725
1060		800x600	1900	1610	2766			2375	1894
1060		800x600	1900		1506	649	220x500	1974	1546
1060		800x600	1900		1506	649	220x500	1974	1712
1060		800x600	1900		1506	649	220x500	1974	1880

## DustStorm® filter

The DustStorm® filter is an under- and over-pressure filter, designed for continuous operation.

Constructed as a self-supporting sheet metal construction. The round design ensures great strength combined with low weight.

### Surface

Powder coated to corrosion class C3 cf. ISO 12944.

### Inlet

Contaminated air passes into the filter through the pressure loss optimised inlet, ensuring optimised separation of the dust particles.

DS-7 and 12 are supplied with total separators.

### Cleaning system

DS-7 EC and DS-12 EC have EC cleaning.

### Discharge system

DustStorm® filter is available with conical or scraper bottom. The DS filter is also available as a silo filter. DS-7 is only available with conical bottom.

### ATEX

DustStorm® filter is fitted with approved explosion membranes with side relief venting. The filters fulfil pressure shock-resistance according to VDI 2263. Venting according to VDI 3673. The DS filter with external compressed air source is supplied ATEX-approved.

### Operating range

Pressure: +/- 5000 Pa

Filter area: 38-188 m<sup>2</sup>

Max. operating temperature: 70°C

Min. operating temperature: -20°C (available down to -40°C)

### Connection DS-12

#### Gear motor scraper bottom:

DS-12-S: 0.25 kW, 15.7 min<sup>-1</sup>, 3 x 400 V, 50 Hz, 1.1 A

#### Inductive sensor scraper bottom:

24 VDC.



## DustStorm® filter

Connection DS-7 EC and DS-12 EC

EC filter control system:

0.2 kW, 1 x 230 V, 50 Hz, 0.8 A

External compressed air – EC cleaning system:

5 bar, min. 400 Nl/min.

Air quality according to ISO 8573-1: 2010 [5:3:4]

External connection: ¼" internal thread.

Integrated fan:

DS-7 E EC: 4.0 kW, 3 x 400 V, 50 Hz, 11.0 A (JK-30MTD)

DS-12 E EC: 11.0 kW, 3 x 400 V, 50 Hz, 19.0 A (JK-40MTD)

Accessories

Ladder/gangway:

Ladder/gangway designed according to ISO/EN/DIN 14122.3/4 and available in several configurations.

Monitoring equipment for explosion membrane.

Door contacts:

2.3 (close-before-switch-contact) in accordance with EN50047, IP67 NC contact.

Noise

Noise level during cleaning measured at 5 m above ground.

DS-7 EC and DS-12 EC: 70.0 dBA

DS-7 EC E: 71.0 dBA

DS-12 EC E: 75.4 dBA



DS-EC-KE R



DS-EC-SE R

## DustStorm® filter with EC cleaning system

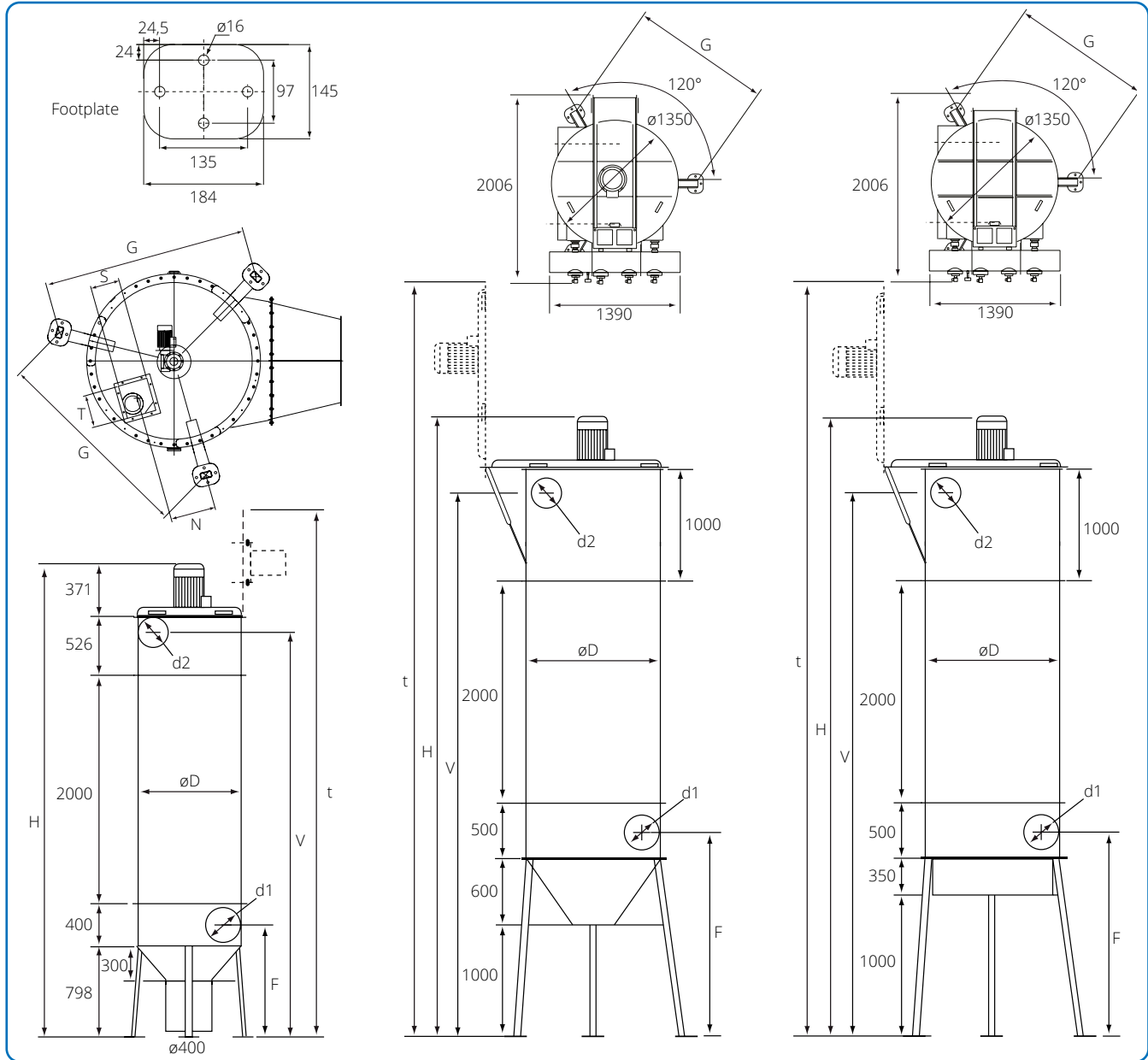

DS-7

DS-12-K

DS-12-S

Type	øD mm	t mm	F mm	V mm	H mm	d1 mm	d2 mm	N mm	S×T mm	G mm	Weight kg
DS-7 EC-K	900	4809	988	3563	3801	300	250	-	-	951	277
DS-7 EC-K E	900	4785	988	3563	4095	300	250	-	-	951	340
DS-12 EC-K	1200	6387	1850	4905	5193	350	350	-	-	1486	534
DS-12 EC-K E	1200	6817	1850	4905	5551	350	350	-	-	1486	656
DS-12 EC-S	1200	6160	1628	4684	4972	350	350	341	220×250	1558	656
DS-12 EC-S E	1200	6400	1628	4684	5330	350	350	290	220×250	1558	778

Weight excluding filter elements

## DustStorm® filter

### Type designations

Filters are type-designated using a combination of letters and numbers separated by hyphens and spaces.

Designation DS-12 EC-K E-R thus describes a DustStorm® filter with 12 filter elements, EC-cleaning system, conical bottom, integrated fan, right inlet

DS-12 EC-K E-R

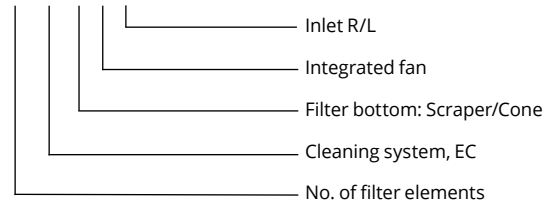

## Jetline® K filter

The JETLINE® K is a dust collector with automatic compressed air cleaning. It operates constantly, providing maximum filtration, particularly in the case of fine dust.

### Surface

Powder coated to corrosion class C3 cf. ISO 12944.

### Inlet

Contaminated air passes into the filter through the pressure loss optimised inlet, ensuring optimum separation of the dust particles.

### Type of dust treated:

Food (chocolate, flour, milk powder), metal, polymer powder, polyurethane brass, zirconium silicate, aluminum oxide, fiberglass, plaster, carbon, plastic, wood, silica, polyethylene, concrete, composite, pigment and many others.

### Triopticlean

- A simple, clean system for removing cartridges in a plastic bag
- A downward flow between the cartridges facilitates settling of dust in the hopper
- Optimal cleaning to eliminate all dust accumulation on top surface



### Cleaning system

Cleaning control sequencer.

The JETLINE® K requires a clean, dry compressed air supply.

Pressure: 4.5 - 6 bar, ISO 8573-1 (class 3.3.3).

### Discharge system

Conical hopper with recovery bin.

### Safety

The JETLINE® K can be fitted with devices to reduce the risk of explosion: antistatic filter cartridges, earthing of metal parts to reduce the effects of electrostatic charge, explosion venting on the top.

### Operating range

Pressure: +/- 5000 Pa

Filter area: 80-600 m<sup>2</sup>

Max. operating temperature: 80°C

Min. operating temperature: -20°C

### Efficiency

The NEU cartridge is manufactured from non-woven polyester with a layer of heat-fused fibres across the whole surface. The perfectly even structure guarantees optimal filtration.

### Maintenance

No tools are required to remove the cartridges. The cartridge removal holder is supplied with the dust collector. As an option, we can supply our "Bag-in/Bag-out" system.

### Characteristics

- + Choice of media to withstand temperatures up to 80°C
- + Reduced pressure drop
- + Pre-assembled and wired in our factory
- + Choice of clean air outlet positions: top or side
- + Modular construction for unlimited range of sizes
- + Optional "Bag-in / Bag-out" arrangement for toxic or hazardous applications
- + Easy access for clean cartridge replacement – no special tools required
- + ATEX version with venting on top

## Jetline® K filter

JETLINE® K with conical bottom

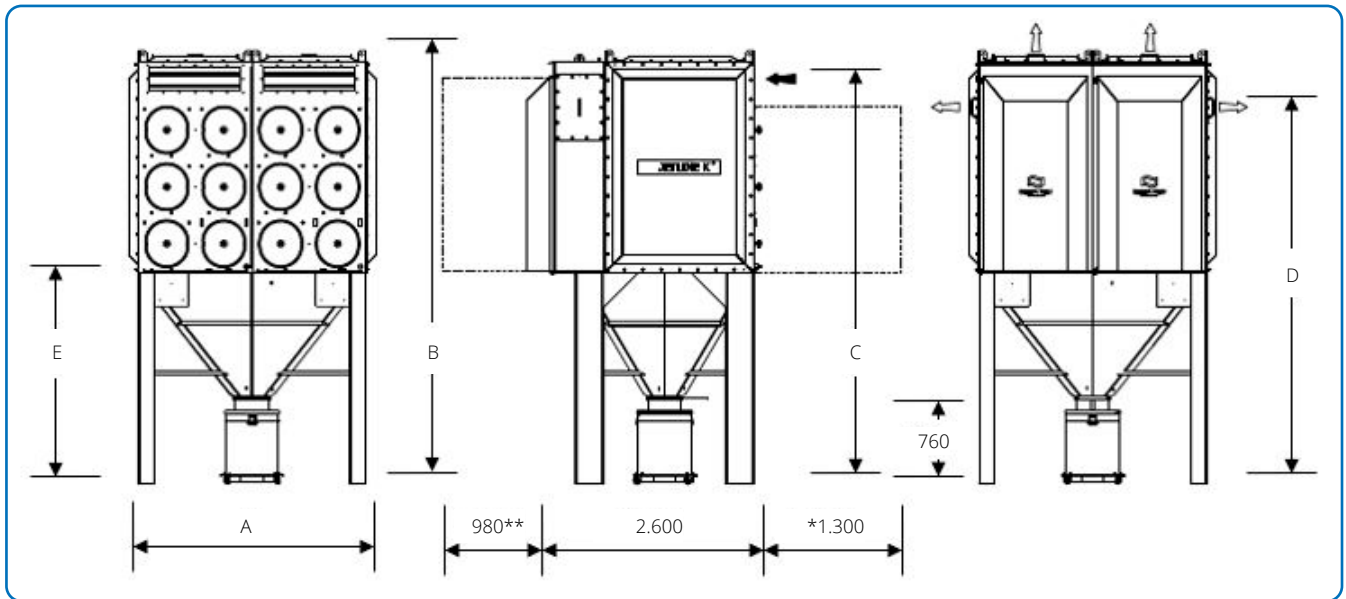

Jetline® K 240-2-6

(\*cartridge extraction, \*\*cover open)

Jetline® K	A (mm)	B (mm)	C (mm)	D (mm)	E (mm)	Weight (kg) JK	Weight (kg) JK ATEX
JK 80-1-4/JK 100-1-4	1170	3050	2800	2550	1600	730	800
JK 120-1-6/JK 150-1-6	1170	3550	3300	3050	1600	800	850
JK 160-1-8/JK 200-1-8	1170	4050	3800	3550	1600	1050	1030
JK 240-2-6/JK 300-2-6	2170	3810	3560	3310	1860	1450	1470
JK 320-2-8/JK 400-2-8	2170	4310	4060	3810	1860	1750	1800
JK 360-3-6/JK 450-3-6	3170	4860	4600	4360	2910	2220	2200
JK 480-3-8/JK 600-2-8	3170	5360	5100	4860	2910	2600	2620

## **Jetline® CH-filter**

IN PREPARATION

**Jetline® CH-filter**

IN PREPARATION

**Poluclean® SI-filter**

IN PREPARATION



**Poluclean® SI-filter**

IN PREPARATION

## SuperJet filters

The SuperJet filters are under- and over-pressure filters designed to run in constant operation. The SuperJet filter is made of high tensile steel to ensure strength combined with low weight. The filter is self-supporting with adjustable legs, and can be erected outdoors or in.

### Fast assembly

SuperJet filters are factory-assembled as standard with a top part, filter body and bottom part, which can be quickly assembled and erected - or of course supplied separately. It is assembled using bolts in high tension steel with integrated washers, significantly reducing assembly time and the risk of over-tightening bolt assemblies.

### Surface

Galvanised sheet, class Z 275 - zinc plating min. 275 g/m<sup>2</sup> double-sided.

### Inlet

The inlet is designed according to the "partial downflow" principle. Contaminated air is passed into the filter and hits a perforated plate which separates most of the dust particles, which settle downwards through the vertical square conduit. The air diffuses through the perforated plate and through the filter bags.

### Cleaning system

PowerPulse® cleaning with ECO-PowerPulse® filter control system.

### Discharge system

The SuperJet filter is supplied with scraper bottom with discharge to a single B-500 rotary valve, but can be increased to two discharges, B-500 or B-750. Also available with discharge to JK-50S and JK-75S.

### ATEX

The filter is fitted with approved explosion membranes. Choose between side venting or JKF's specially developed VFV® explosion relief venting, which vents explosion pressure vertically through the filter top. The filters fulfil pressure shock-resistance according to EN 14460. Venting according to EN 14491.

The filter is risk assessed in accordance with EN 1127-1 and CE-marked to have an internal zone 21 on the dirty side of the filter and zone 22 on the clean air side of the filter.

### Operating range

Pressure: +/- 5000 Pa  
 Filter area: 172 - 269 m<sup>2</sup>  
 Max. operating temperature: 65°C  
 Min. operating temperature: -20°C (available for -40°C)

### Connection

#### Gear motor scraper bottom:

0.75 kW, 7.8 min<sup>-1</sup>, 3x400 V, 50 Hz, 2.7 A

#### Inductive sensor scraper bottom:

24 VDC

#### ECO-PowerPulse® filter control system:

0.3 kW, 3x400 V, 50 Hz, 1.1 A (16 A)



## SuperJet filters

### External compressed air - PowerPulse®:

6.5 - 8.0 bar, min. 650 NI/min.

Air quality according to ISO 8573-1: 2010 [5:3:4]

External connection: ¼" internal thread.

### Noise

Noise level during cleaning measured 5 m above the ground: 69.8 dBA

### Accessories

#### Ladder/gangway:

Ladder/gangway designed according to ISO/EN/DIN 14122.3/4 and available in several configurations: Ladder with gangway, side-mounted or ladder with double gangway, side-mounted.

Monitoring apparatus for explosion membrane.

#### Door contacts:

2.3 (close-before-switch-contact) in accordance with EN50047, IP67 NC contact.

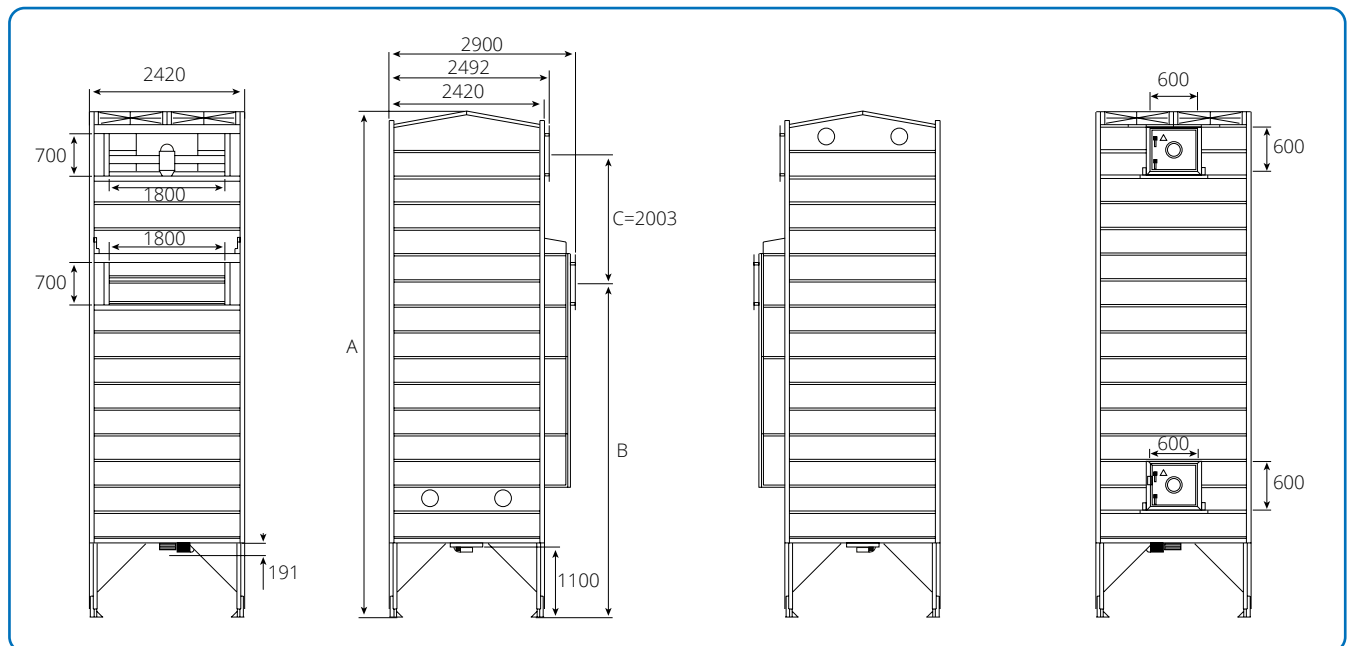
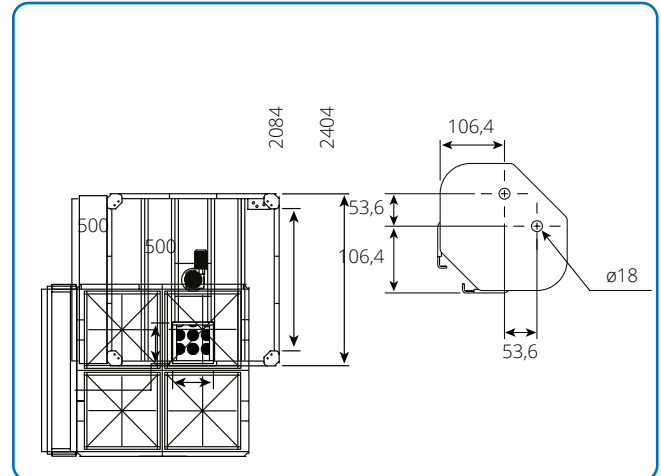

Type	Bag length m	Filter area m <sup>2</sup>	A mm	B mm	Weight kg
SuperJet-3	3.0	172	7058	4411	3350
SuperJet-4	4.0	220	7858	5211	3790
SuperJet-5	5.0	269	8658	6011	4110

## MMBF filters

The MMBF filters (Multi Modular Bag Filter) are under- and over-pressure filters designed to run in constant operation. They are modular and can therefore be added in line with growing capacity requirements and can be adapted to any task. More modules can subsequently be added, or they can be rebuilt to a different height or other material transport system to meet changed extraction needs. The MMBF filter is made of high tensile steel to ensure strength combined with low weight. The filter is self-supporting with adjustable legs, and can be erected outdoors or in.

### More efficient operation

The number of filter bags per module is 30. This means large filter area and low riser speed in the filter for a given air volume. The perforated sheet is shaped to avoid chafing the filter bags. The bags are antistatic with a large diameter (220) and fitted with a snap ring fastener, reducing dust particle retention, enabling more efficient bag cleaning. The result is lower pressure loss and reduced risk of blockage. The partition wall between the modules makes continuous cleaning easy during operation.

### Fast assembly

MMBF filters are factory-assembled as standard. A top and bottom part are delivered which can quickly be erected and assembled. The filters can also be supplied unassembled. The filter is multi-modular, and can be assembled using bolts in high tension steel with integrated washers, significantly reducing assembly time and the risk of over-tightening bolt assemblies.

### Surface

Galvanised sheet, class Z 275 - zinc plating min. 275 g/m<sup>2</sup> double-sided.

### Inlet

The MMBF filter is supplied with the supply air chamber in the conical bottom. Side inlet 300×400 mm is standard, but it can also be supplied with one and two end inlets 400×500 mm. The standard inlet is supplied with contra-flaps, which are open during normal filter operation, but close when the fan is switched off. The flaps prevent the air flow created by the regenerating fan returning into the pipe system.

### Outlet

The MMBF filter has a built-in return air conduit. The outlet from the return air conduit is available with an exhaust damper with mechanical melting fuse (69°). Filter type H outlet is 450×950 mm and filter type E is 600×950 mm.

### Cleaning system

The regenerating fan ensures easy, effective filter bag cleaning. One module at a time is regenerated, as there are partition walls between the modules.

### Discharge system

Screw, rotary valve or bucket discharge systems are available.

The MMBF screw is available in 2 to 12 modules. The screw is ø180 mm and made of AISI 304 and supplied as standard with 22 min<sup>-1</sup> or 43 min<sup>-1</sup>.

The MMBF rotor filter is available with 1 to 4 modules and with JK-50S, JK-100S, JK-150S or JK-200S.

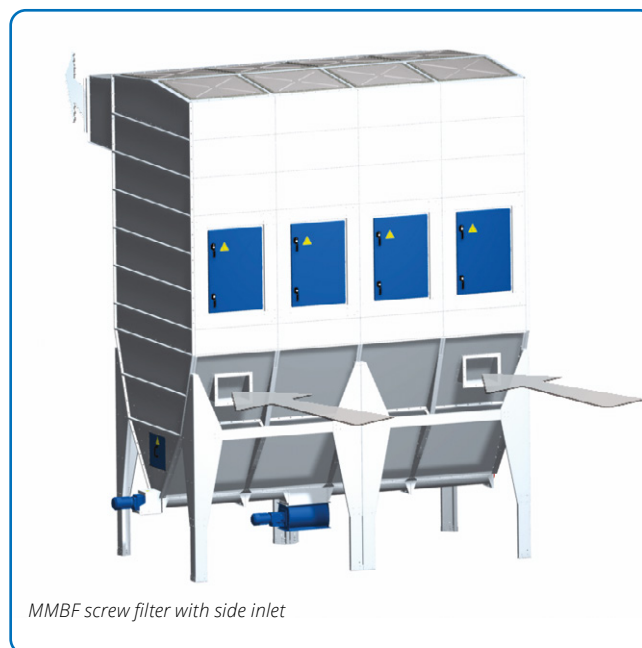
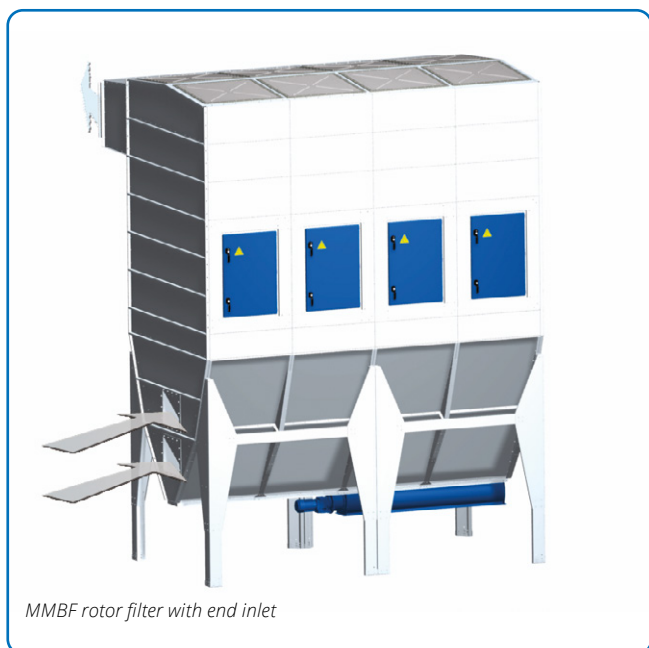

The MMBF bag emptying filter is available with 1 to 4 modules with a dust bucket under each. Buckets are supplied fully assembled direct from JKF, fitted with inspection glass to give a good indication of fill status. Easily mounted, using a clamp with uniform key code.

The filter is fitted with a pressure-equalisation hose to prevent the bag being sucked up during startup at underpressure. Hose can be easily disconnected using a compressed air coupling.

**ATEX**

The MMBF filter is ATEX-approved and has approved explosion membranes. Choose between side venting in the cone (ERH) 600x600 KER or JKF's specially developed VFV® explosion venting (ERR) 920x920 KER, which vents vertically through the filter top.

**Operating range**

- Pressure: +/- 5000 Pa
- Filter area: 41.7-612 m<sup>2</sup>
- Max. operating temperature: 70°C
- Min. operating temperature: -20°C (available for: -40°C)

**Connection**

**Motor**

Regenerating fan

H filter ø450: 1.5 kW, 2900 min<sup>-1</sup>, 3x400 V, 50 Hz, 3.2 A

E filter ø600: 1.5 kW, 1450 min<sup>-1</sup>, 3x400 V, 50 Hz, 3.2 A

**Screw**

0.55 kW, 22 min<sup>-1</sup>, 3x400V, 50 Hz, 2.5 A

0.75 kW, 43 min<sup>-1</sup>, 3x400V, 50 Hz, 3.2 A

**Filter bags**

30 filter bags per module

**Type designations**

Filters are type-designated using a combination of letters and numbers separated by hyphens and spaces. Designation MMBF-4M E D-ERH-id/4/o/1 thus describes a MMBF filter with 4 modules, height, double filter, explosion relief venting in the cone, inlet in module 4, exhaust damper with mechanical melting fuse (69°) in module 1.

MMBF-4M E D-ERH-id/4/o/1

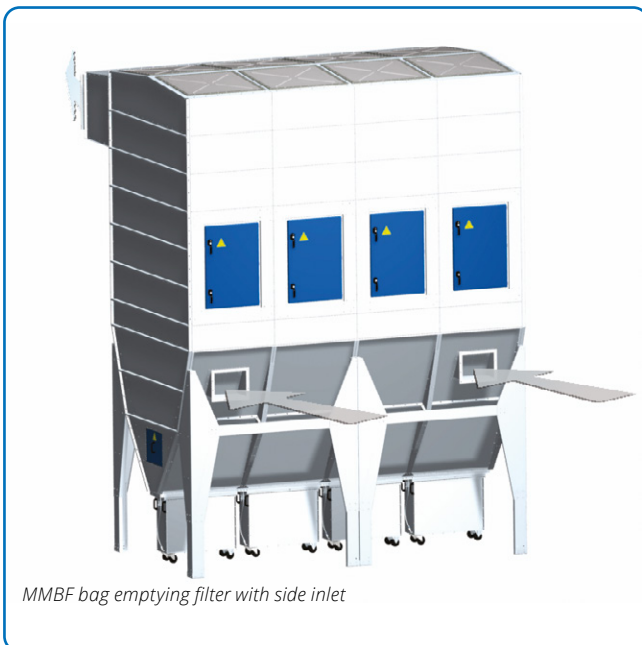
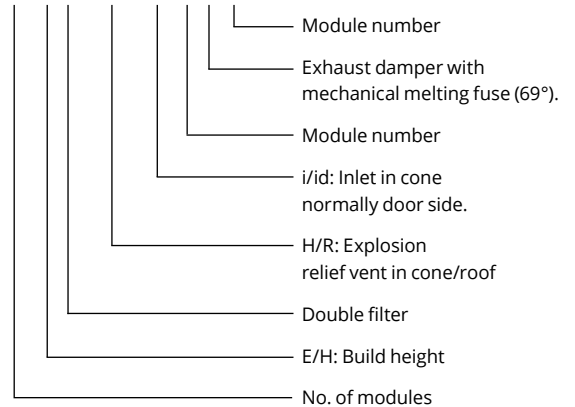

## MMBF filters

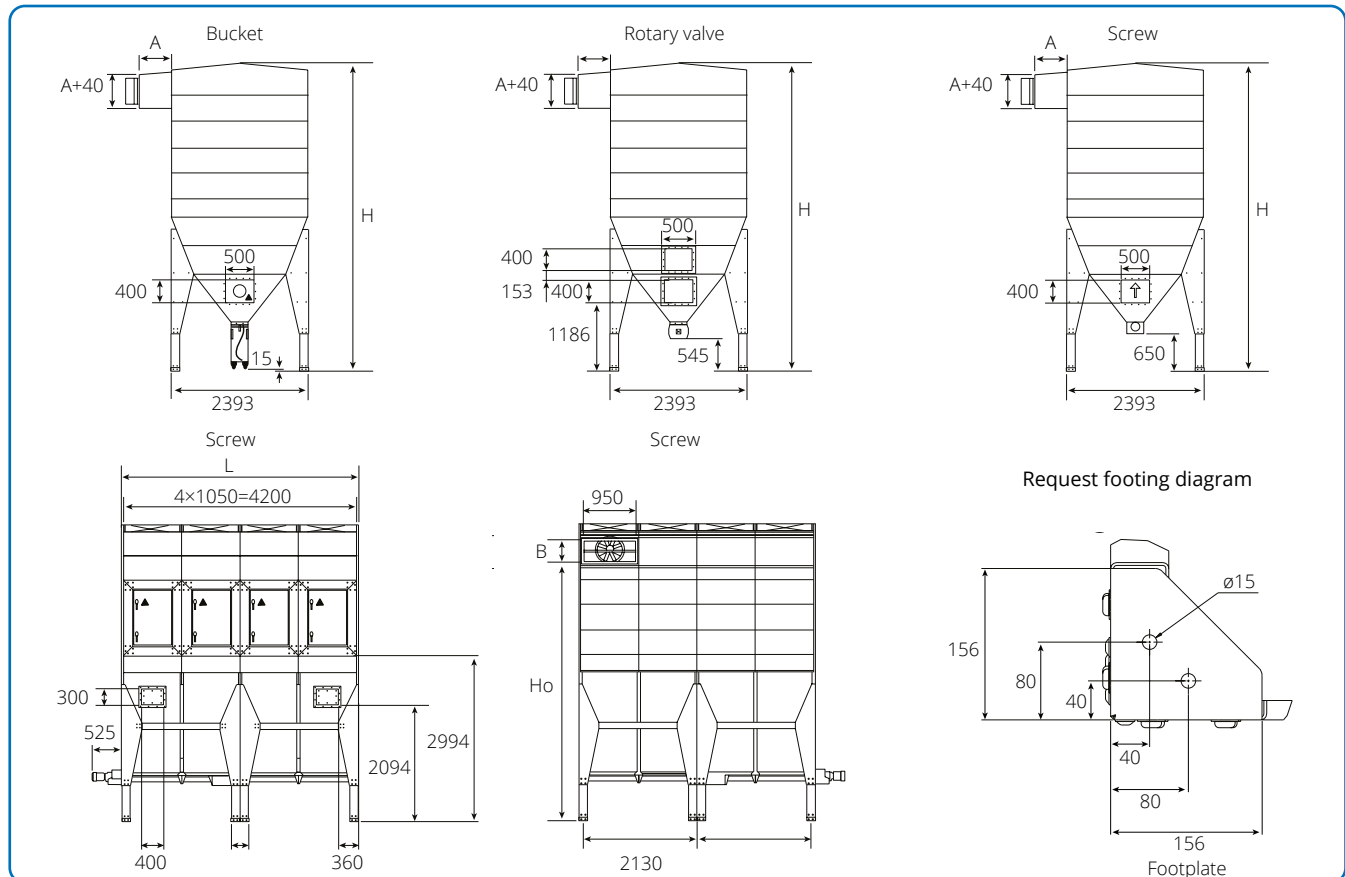

Discharge			Type			Filter area m <sup>2</sup>	H mm	Ho mm	L mm	A mm	No. of legs	Bucket kg	Rotary valve kg	Screw kg	B	
Bucket	Rotary valve	-	MMBF	1	M HD	ERH/ERR	41.7	5350	4660	1130	550	4	1137	1205	-	400
Bucket	Rotary valve	-	MMBF	1	M ED	ERH/ERR	51.0	5800	4910	1130	750	4	1220	1289	-	600
Bucket	Rotary valve	Screw	MMBF	2	M HD	ERH/ERR	83.4	5350	4660	2130	550	4	1656	1655	1770	400
Bucket	Rotary valve	Screw	MMBF	2	M ED	ERH/ERR	102.0	5800	4910	2130	750	4	1823	1822	1937	600
Bucket	Rotary valve	Screw	MMBF	3	M HD	ERH/ERR	125.1	5350	4660	3180	550	4	2335	2324	2418	400
Bucket	Rotary valve	Screw	MMBF	3	M ED	ERH/ERR	153.0	5800	4910	3180	750	4	2588	2557	2681	600
Bucket	Rotary valve	Screw	MMBF	4	M HD	ERH/ERR	166.8	5350	4660	4280	550	8	3215	3183	3190	400
Bucket	Rotary valve	Screw	MMBF	4	M ED	ERH/ERR	204.0	5800	4910	4280	750	8	3468	3446	3489	600
-	-	Screw	MMBF	5	M HD	ERH/ERR	208.5	5350	4660	5330	550	8	-	-	3890	400
-	-	Screw	MMBF	5	M ED	ERH/ERR	255.0	5800	4910	5330	750	8	-	-	4255	600
-	-	Screw	MMBF	6	M HD	ERH/ERR	250.2	5350	4660	6380	550	12	-	-	4590	400
-	-	Screw	MMBF	6	M ED	ERH/ERR	306.0	5800	4910	6380	750	12	-	-	5021	600
-	-	Screw	MMBF	7	M HD	ERH/ERR	291.9	5350	4660	7430	550	12	-	-	5290	400
-	-	Screw	MMBF	7	M ED	ERH/ERR	357.0	5800	4910	7430	750	12	-	-	5787	600
-	-	Screw	MMBF	8	M HD	ERH/ERR	333.6	5350	4660	8480	550	16	-	-	5990	400
-	-	Screw	MMBF	8	M ED	ERH/ERR	408.0	5800	4910	8480	750	16	-	-	6553	600
-	-	Screw	MMBF	9	M HD	ERH/ERR	375.3	5350	4660	9530	550	16	-	-	6690	400
-	-	Screw	MMBF	9	M ED	ERH/ERR	459.0	5800	4910	9530	750	16	-	-	7319	600
-	-	Screw	MMBF	10	M HD	ERH/ERR	417.0	5350	4660	10580	550	20	-	-	7390	400
-	-	Screw	MMBF	10	M ED	ERH/ERR	510.0	5800	4910	10580	750	20	-	-	8085	600
-	-	Screw	MMBF	11	M HD	ERH/ERR	458.7	5350	4660	11630	550	20	-	-	8090	400
-	-	Screw	MMBF	11	M ED	ERH/ERR	561.0	5800	4910	11630	750	20	-	-	8851	600
-	-	Screw	MMBF	12	M HD	ERH/ERR	500.4	5350	4660	12680	550	24	-	-	8790	400
-	-	Screw	MMBF	12	M ED	ERH/ERR	612.0	5800	4910	12680	750	24	-	-	9617	600

## Modular filters

JKF's modular dust filters are bag filters. Modular filters can have up to 30 single or double modules, and with various discharge systems: silo, blow through, bag emptying, rotary valve, screw or chain.

They are made of 1.25 and 2 mm galvanised sheet metal.

The standard filter medium is PE40/PE25 bags. The filters are available with different bag lengths, depending on requirements.

The exhaust dampers has a 69°C thermal protection fuse and micro-switch connected to the plant's main fan.

The number of exhaust dampers and doors depends on the number of modules. See table.

No. of modules	No. of exhaust dampers		No. of doors	
	Single	Double	Single	Double
1	1	1	1	1
2	1	1	1	2
3	1	2	2	3
4	2	2	2	4
5	2	3	3	5
6	3	3	3	6
7	3	4	4	7
8	4	4	4	8
9	4	5	5	9
10	5	5	5	10
11	5	6	6	11
12	6	6	6	12

### Optional extras

Chain filter type CDF is fitted as standard with a regeneration fan for cleaning filter bags. Other modular filters are available with shaker device or ø450 mm regenerating fan for cleaning the filter bags (ø600 for EX).

Filter height is increased by 150 mm if a shaker device is fitted. The height is increased by 300 mm if a regenerating fan is fitted.

### ATEX

Modular filters are not ATEX-approved.

### Operating range

Pressure:	+ 2500 Pa
Filter area:	15.5-1740 m <sup>2</sup>
Max. operating temperature:	70°C
Min. operating temperature:	- 20°C

### Connection

#### Motor:

Regenerating fan

ø450 1.5 kW, 2900 min<sup>-1</sup>, 3 x 400 V, 50 Hz, 3.2 A

ø600 1.5 kW, 1450 min<sup>-1</sup>, 3 x 400 V, 50 Hz, 3.2 A

Shaking mechanism

0.75 kW, 121 min<sup>-1</sup>, 3 x 400 V, 50 Hz, 2.2 A

Screw

0.55 kW, 22 min<sup>-1</sup>, 3 x 400 V, 50 Hz, 2.5 A

Chain

0.75 kW, 17.5 min<sup>-1</sup>, 3 x 400 V, 50 Hz, 2.2 A

State number of modules, single or double, filter height/bag length, number of exhaust dampers and doors, location of supply air and any optional extras when ordering.

If several fans are used for the same filter, a JKF contra-damper must be used on the inlets.

## Silo filter type PL-PLD

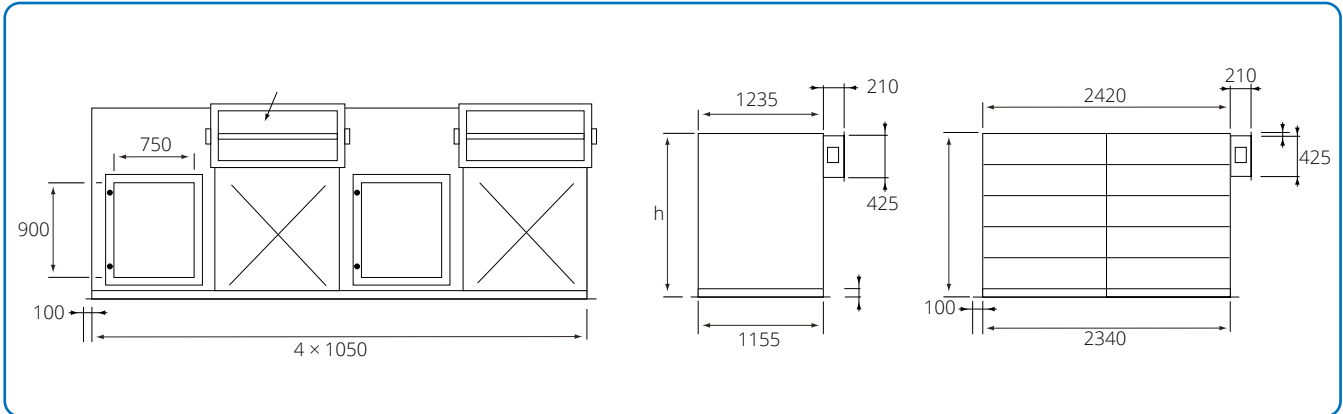

The drawing above shows single and double filters. Measurement specifications are stated in the table at the bottom of the page.

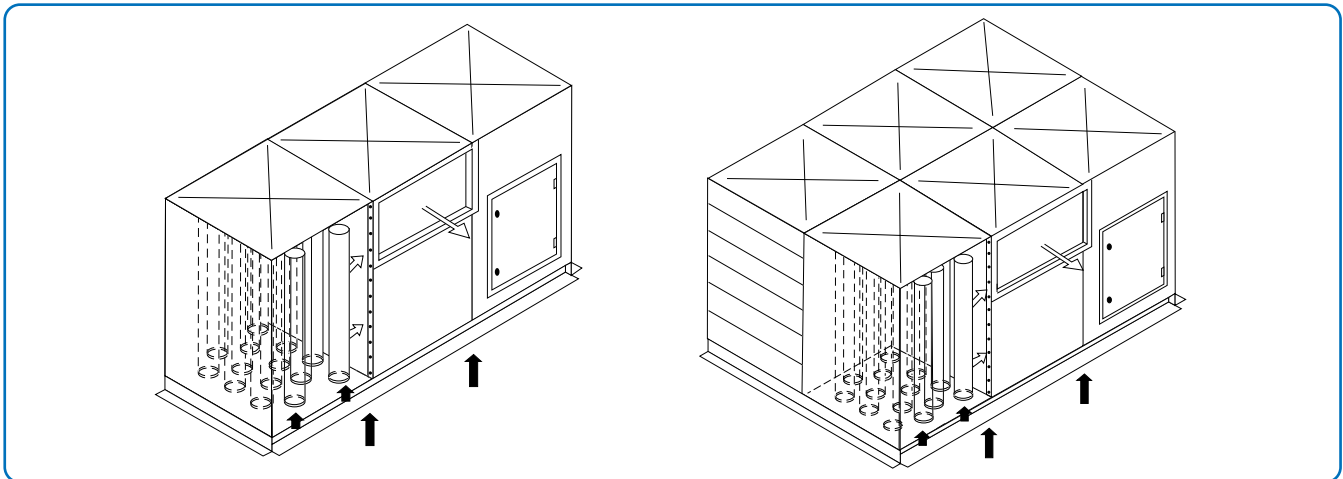

Silo filter type PL and double silo filter type PLD.

Silo filter type PL and PLD is a bag filter. The filter is used on a flat silo top so that the contaminated air flows directly against the underside of the bag bottom and up through the bags for separation.

Type mm	Dimensions			
	h mm	Bag length mm	Filter area m <sup>2</sup> per module	Weight per module kg
M - PL	1750	1580	15.5	125
H - PL	2200	2030	20.0	140
E - PL	2650	2480	24.5	155
M - PLD	1750	1580	31.0	215
H - PLD	2200	2030	40.0	240
E - PLD	2650	2480	49.0	265



## Blow through filter type L-LD

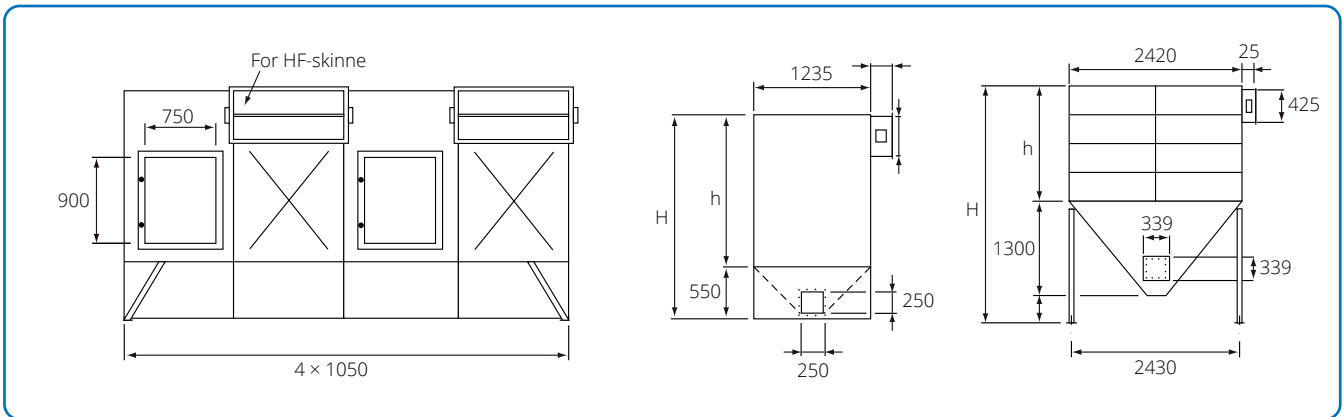

The drawing above shows single and double filters. Measurement specifications are stated in the table at the bottom of the page.

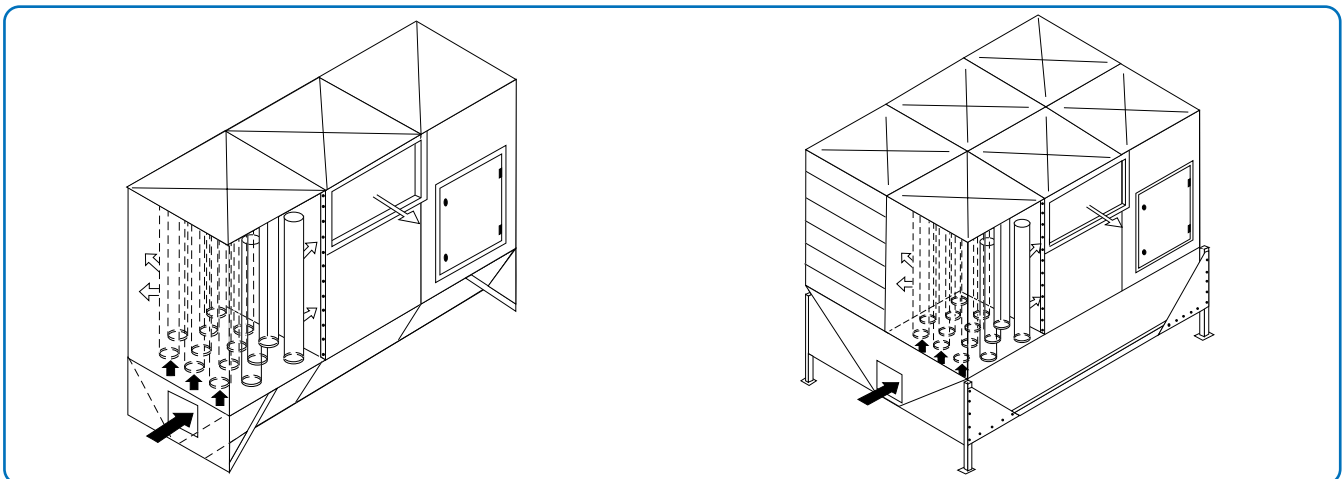

Blow through filter type L and double blow through filter type LD.

Blow through filter types L and LD are bag filters. They are used for extraction from minor applications, max. 4 HDL modules. The filter has automatic emptying. Emptying is achieved using a secondary fan which extracts the material. The secondary fan represents a suction force of approx. 25% of the primary fan's air volume.

Type	Dimensions				
	mm	h mm	H mm	Bag length mm	Filter area m <sup>2</sup> per module
M - L	1650	2200	1580	15,5	120
H - L	2100	2650	2030	20,0	135
M - LD	1650	3050	1580	31,0	230
H - LD	2100	3500	2030	40,0	260

## Bag emptying filter type LS-LSD

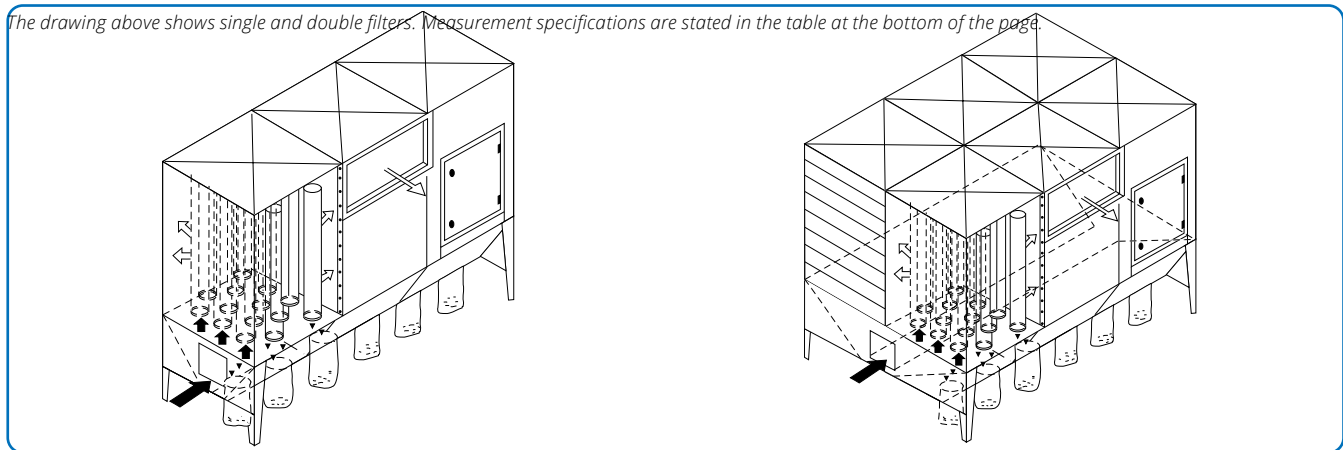
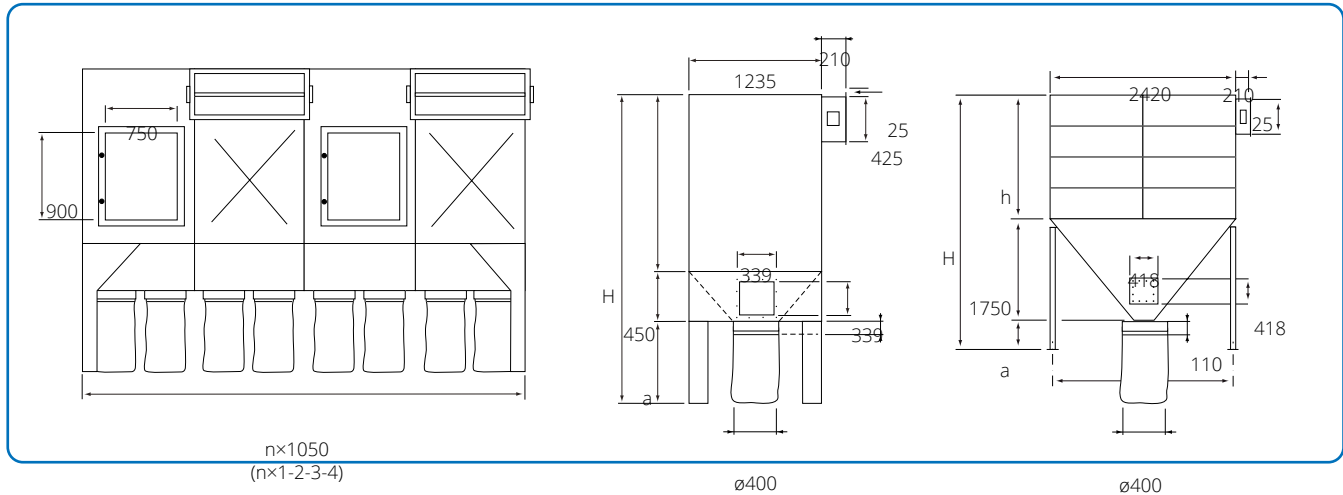

Bag emptying filter type LS and double bag emptying filter type LSD.

Bag emptying filter type LS - LSD is used for minor applications and can be fitted indoors and out.  
The filter is emptied manually by removing full plastic sacks or buckets.  
The filter is supplied as standard with sacks.

Standard inlet location is at the end of the filter, but it can be located at the side of the bottom.  
Double filters are available with air supply chamber the full width of the chamber, 1050 mm.

Type mm	Dimensions						Weight per module kg
	h mm	a mm	H mm	Bag length mm	Filter area m <sup>2</sup> per module		
M - LS	1650	780	2880	1580	15,5	125	
M - LS	1650	1200	3300	1580	15,5	135	
H - LS	2100	780	3330	2030	20,0	140	
H - LS	2100	1200	3750	2030	20,0	150	
E - LS	2550	780	3780	2480	24,5	155	
E - LS	2550	1200	4200	2480	24,5	165	
M - LSD	1650	780	4180	1580	31,0	305	
M - LSD	1650	1200	4600	1580	31,0	330	
H - LSD	2100	780	4630	2030	40,0	325	
H - LSD	2100	1200	5050	2030	40,0	350	
E - LSD	2550	780	5080	2480	49,0	345	
E - LSD	2550	1200	5500	2480	49,0	370	

## Rotor filter type HL-HLD

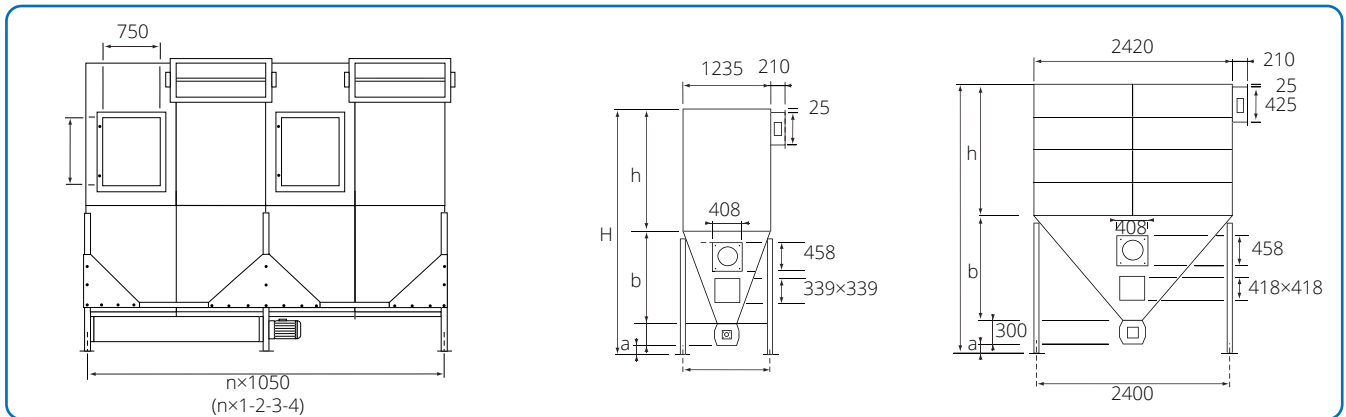

The drawing above shows single and double filters. Measurement specifications are stated in the table at the bottom of the page.

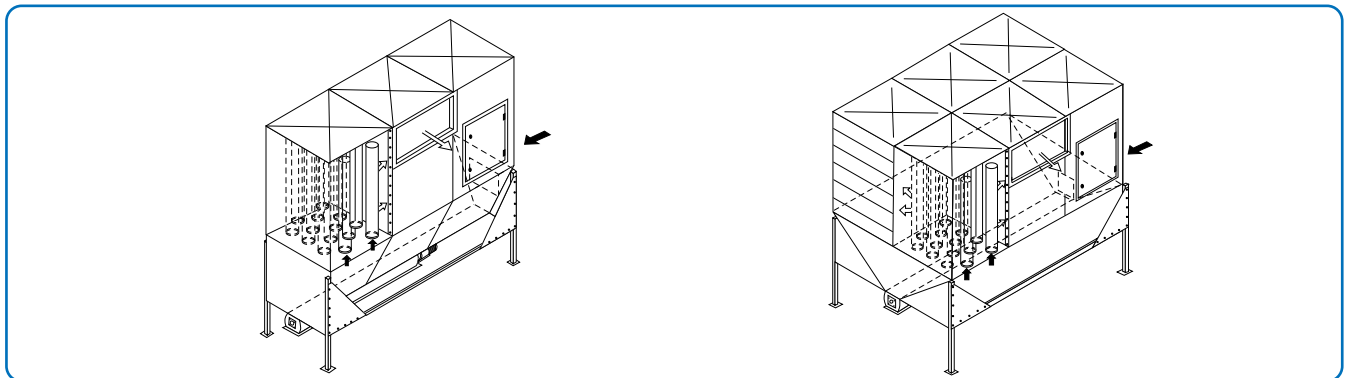

Rotor filter type HL and double rotor filter type HLD.

Rotor filter type HL - HLD is used for installation on silo tops, above containers, or wherever the transport of chips to a refuse depot is required using a ring pipe.

Supply air enters at the end of the filter opposite the rotary valve, or in the air supply chamber.

The filter can be emptied using a rotary valve, the size of which is governed by requirement.

Type	Dimensions				Bag length mm	Filter area m <sup>2</sup> per module	Weight per module kg
	a mm	b mm	h mm	H mm			
M - HL	100	1340	1650	3390	1580	15.5	225
M - HL	350	1340	1650	3640	1580	15.5	230
H - HL	100	1340	2100	3840	2030	20.0	240
H - HL	350	1340	2100	4090	2030	20.0	245
E - HL	100	1340	2550	4290	2480	24.5	255
E - HL	350	1340	2550	4540	2480	24.5	260
M - HLD	100	1860	1650	3910	1580	31.0	305
M - HLD	350	1860	1650	4160	1580	31.0	305
H - HLD	100	1860	2100	4360	2030	40.0	325
H - HLD	350	1860	2100	4610	2030	40.0	325
E - HLD	100	1860	2550	4810	2480	49.0	345
E - HLD	350	1860	2550	5060	2480	49.0	345

## Screw filter type S-SD

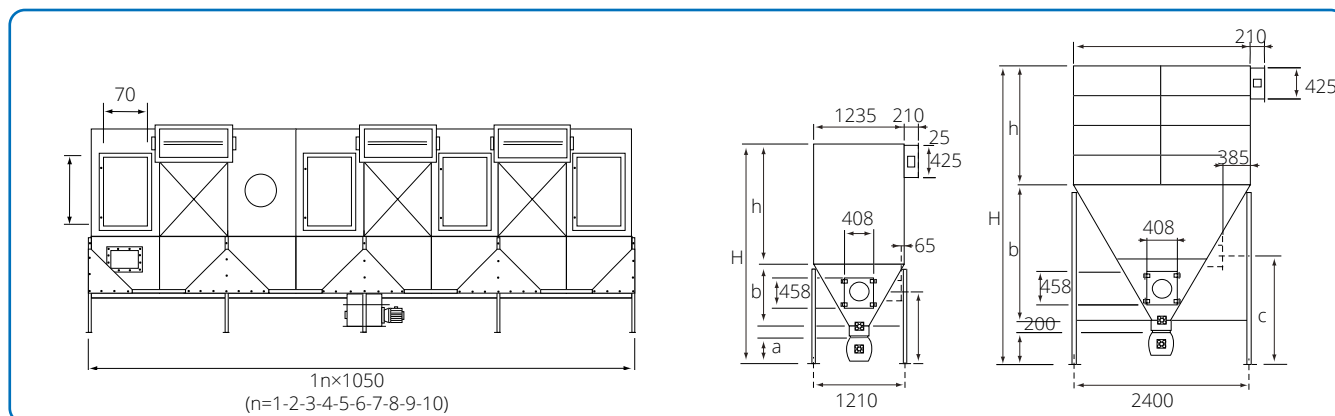

The drawing above shows single and double filters. Measurement specifications are stated in the table at the bottom of the page.

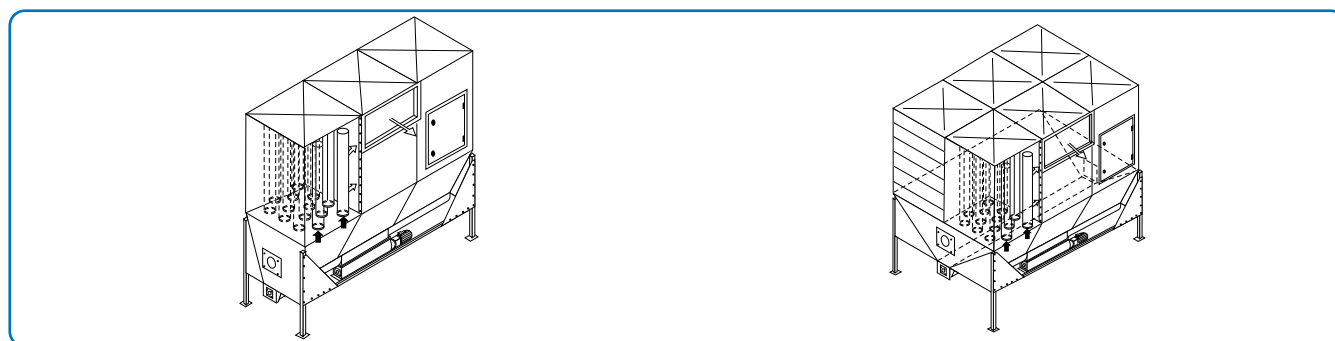

Screw filter type S and double screw filter type SD.

The S - SD screw filter can be used for heavy-duty applications involving large volumes of materials and air.

Supply air enters at the side of the bottom or in a separate air supply module, although never over the material discharge.

If several fans are used for the same filter, a JKF nonreturn flap must be used on the inlets.

The filter is emptied using a screw with discharge from either end towards the middle of the filter, or from one end towards the discharge at the opposite end. The discharge can be located where required.

### Connection

Screw

Gear motor

0.55 kW, 22 min<sup>-1</sup>, 3 x 400 V, 50 Hz, 2.5 A

### Dimensions

Type	a mm	b mm	c mm	h mm	H mm	Bag length mm	Filter area m <sup>2</sup> per module	Weight per module kg
M - S	400	840	1080	1650	3090	1580	15.5	155
M - S	650	840	1330	1650	3340	1580	15.5	160
H - S	400	840	1080	2100	3540	2030	20.0	170
H - S	650	840	1330	2100	3790	2030	20.0	175
E - S	400	840	1080	2550	3990	2480	24.5	185
E - S	650	840	1330	2550	4240	2480	24.5	190
MS - D	400	1860	1545	1650	4110	1580	31.0	310
MS - D	650	1860	1795	1650	4360	1580	31.0	315
HS - D	400	1860	1545	2100	4560	2030	40.0	330
HS - D	650	1860	1795	2100	4810	2030	40.0	335
ES - D	400	1860	1545	2550	5010	2480	49.0	350
ES - D	650	1860	1795	2550	5260	2480	49.0	355
EX - D	650	1860	1795	3000	5710	2890	58.0	375

## Chain filter type CDF

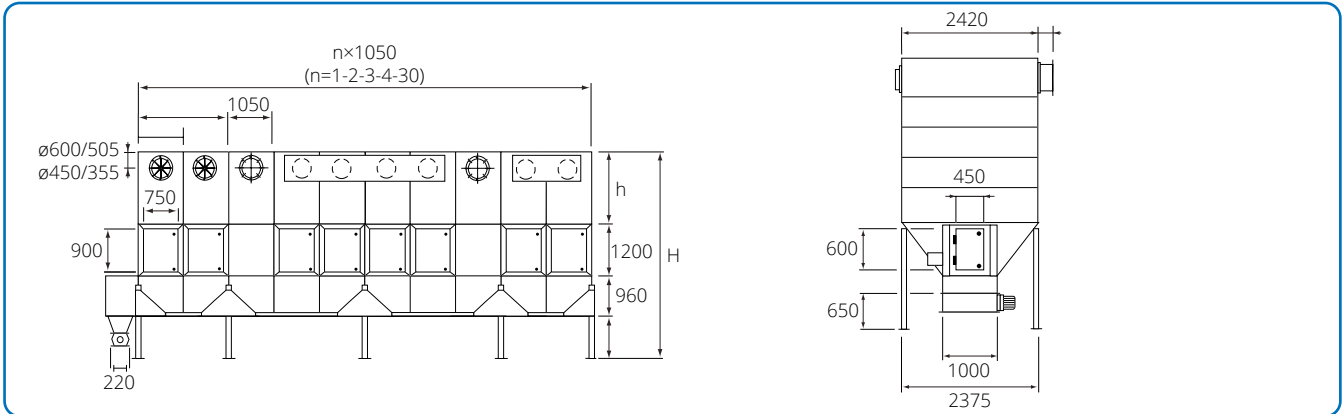

The drawing above shows a double filter. Measurement specifications are stated in the table at the bottom of the page.

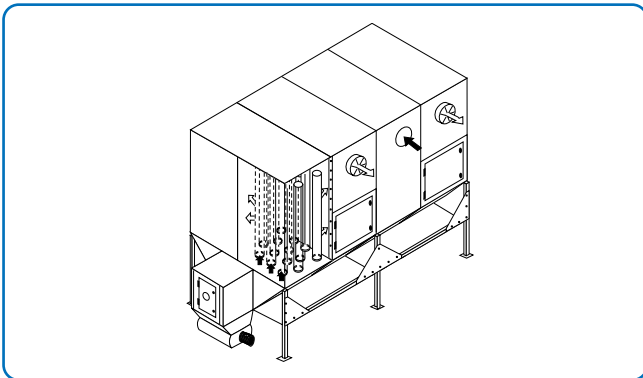

Chain filter type CDF.

The CDF chain filter can be used for heavy-duty applications involving large volumes of materials and air.

Air is fed in to one or several separate supply air modules – always min. 2-3 modules away from the material discharge.

The filter can be emptied using a conveyor mounted on a chain which transports the material from the bottom of the filter towards the discharge, placed at one end of the filter.

### Connection

Chain

Gear motor

0.75 kW, 175 min<sup>-1</sup>, 3 x 400 V, 50 Hz, 2.2 A

Supplied as standard with 1 x regeneration fan  $\varnothing 450$  mm per module or  $\varnothing 600$  mm for EX.

### Optional extras

Safety control system for emptying material discharge and rotary valve, equipped with impulse sensors to stop discharge in the event of fault or overload.

Dimensions						
Type	H mm	h mm	Bag length mm	Filter area m <sup>2</sup> per module	Weight per module kg	
HCDF	4510	1200	1990	40	325	
ECDF	4960	1650	2440	49	345	
EXCDF	5410	2100	2850	58	365	

## Point filter type PKF

The compressed air-cleaned point filter is a miniature bag filter for mounting direct on transport machines (horizontally or vertically).

Dust separated in the filter is fed back into the material flow to avoid mixing different materials.

The point filter has a simple and functional design, making mounting on transport pipes and cup elevators very simple.

Filter bag replacement can be easily executed from the big inspection hatch.

The point filter is manufactured from 2 mm galvanized sheet or in stainless steel and is supplied in 2 versions:

1. With doors for horizontal mounting
2. With doors for vertical mounting

### Connections:

Filter control: 220 V, 50 Hz, 2 W

Fan: 3×380 V, 50 Hz, 1.1 kW

Vertical: Inclined bottom

### Compressed air:

5 bar, min. 350 NI/min.

Air quality according to ISO 8573-1: Quality class (5, 4, 4)

External connection: ¼" internal thread.

### Cleaning system:

The filter bags are automatically cleaned by means of compressed air through an electronic control with adjustable pulse- and break time.

Sealing class IP 65.

Type	Cleaning pressure [bar]	Pulse time [sec]	Break time [min]
PKF-1,5	3,0	0,5	30
PKF-2,0	3,5	0,5	30
PKF-2,5	4,0	0,5	30
PKF-3,0	5,0	0,5	30

Recommended settings of control of compressed air.

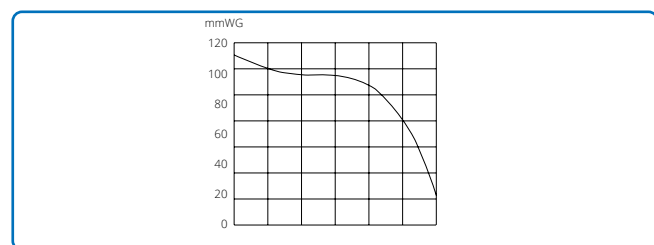

Fan type N 602

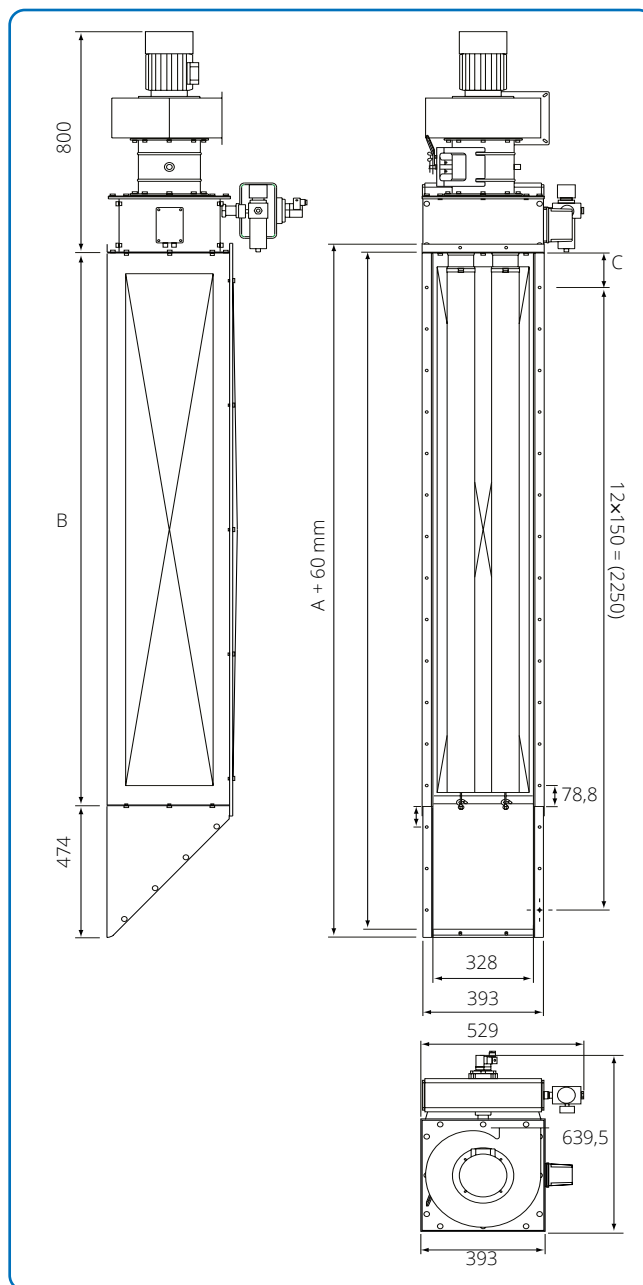

Type	Dimensions						
	A mm	B mm	C mm	Bag length mm	Air capacity max. m³/h	Filter area m²	Weight kg
PKF-1,5	1943	1500	75	1400	1000	2,1	132
PKF-2,0	2443	2000	125	1900	1500	2,9	155
PKF-2,5	2943	2500	25	2400	2000	3,6	178
PKF-3,0	3333	2900	115	2800	2250	4,2	196

## Intake filter

The intake filter is a bag filter intended for continuous operation.

The filter medium is cleaned by compressed air.

A filter control system to control filter cleaning is available which permits adjustment of the cleaning frequency, reducing the amount of compressed air used and ensuring maximum utilisation of intake filters.

Intake filters consist of 2 mm bolted galvanised panels. This method of assembly makes it easier to replace parts on site.

Bag length can be varied according to requirement from 1.5 m to 3.5 m. Standard filter medium is PE40/PE25, but others are available to order.

Available as wall or floor mounted (the latter on a plinth).

The return air system can be fitted with an automatic shut-off damper connected to the filter control system, to increase cleaning effect.

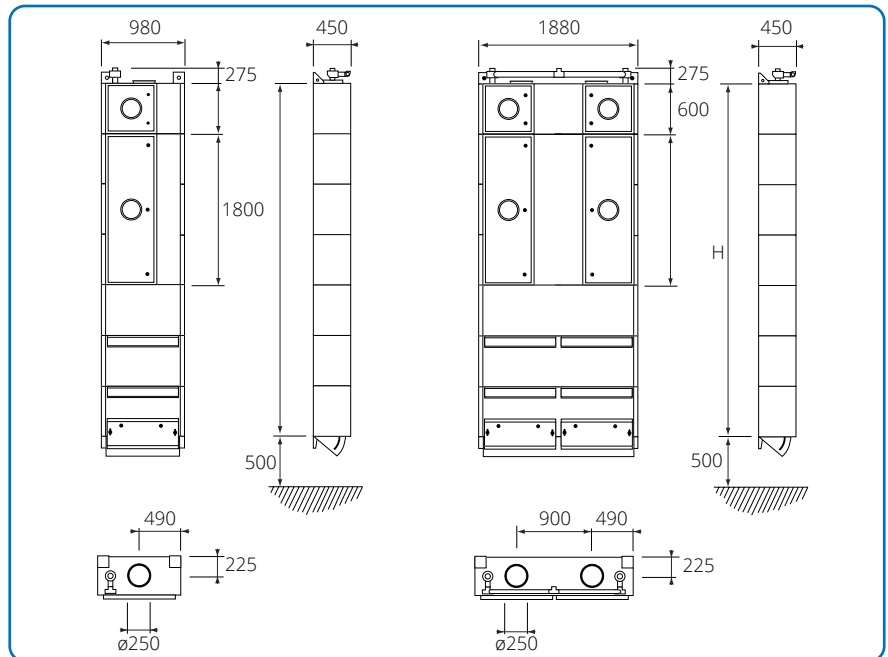

Specifications for single type P intake filter and double type PD are given below.

Cleaning pressure: 4-5 bar in dry air.

Power supply: 230 V

Noise level: 80 dBA

Operating temperature: Max. 65°C

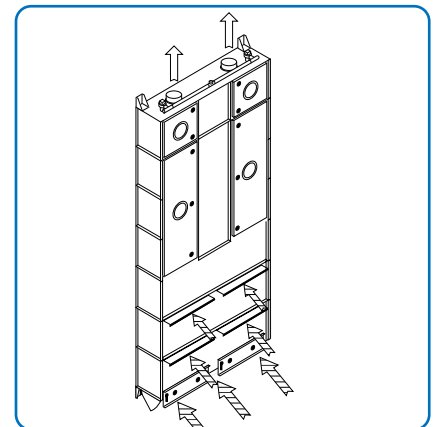

Double intake filter type PD.

Type	Dimensions			Weight kg	Air consumption NL/MIN
	Bag length m	Filter area m <sup>2</sup>	H mm		
P-1.5	1.5	5.0	3000	195	250
P-2.0	2.0	6.6	3000	200	340
P-2.5	2.5	8.2	3600	230	425
P-3.0	3.0	9.9	3600	235	500
P-3.5	3.5	11.5	4200	260	600
PD-1.5	1.5	9.9	3000	355	500
PD-2.0	2.0	13.2	3000	370	680
PD-2.5	2.5	16.5	3600	420	850
PD-3.0	3.0	19.8	3600	435	1000
PD-3.5	3.5	23.1	4200	470	1200

## Movable dust filter type JK-12 TS, JK-20 TS, JK-22 TS and JK-25 TSD

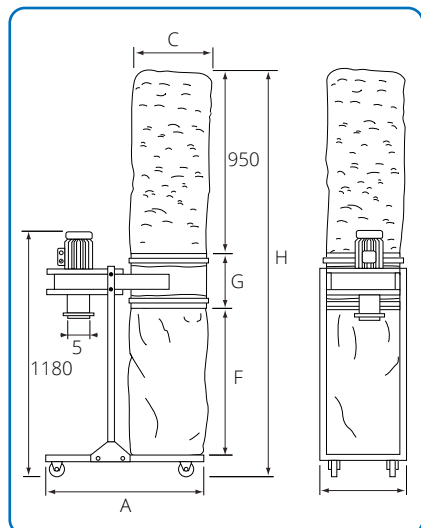

Type JK-12 TS. Dimensions stated in mm.

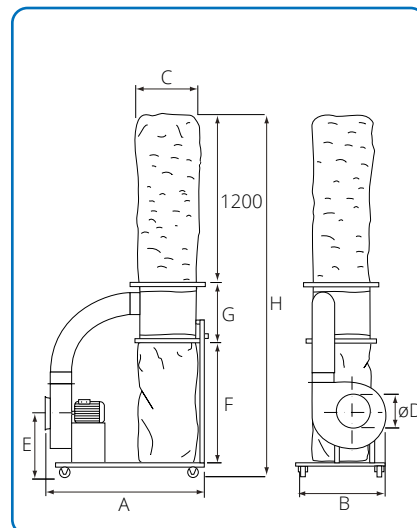

Type JK-20 TS and JK-22 TS.

Movable dust filters from 0.75 kW to 4 kW are ideal for small extraction tasks, e.g. from one or two machines.

The filter medium is polyester.

All filters are fitted with removable refuse sacks with self-tightening snap-lock fittings for rapid replacement.

Movable dust filters can be connected to pipes or Vena-Pur flexible hoses.

Type JK-12 TS with a 0.75 kW motor produces 700 m<sup>3</sup>/h at a pressure of 70 mmVS.

Type JK-20 TS with a 1.1 kW motor produces 1,800 m<sup>3</sup>/h at a pressure of 120 mmVS.

Type JK-22 TS with a 2.2 kW motor produces 2,500 m<sup>3</sup>/h at a pressure of 160 mmVS.

Type JK-25 TSD with a 4.0 kW motor produces 3,500 m<sup>3</sup>/h at a pressure of 190 mmVS.

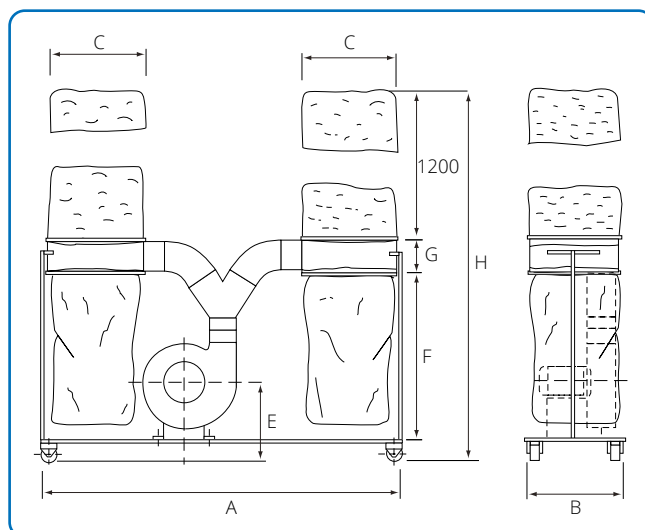

Type JK-25 TSD. Dimensions stated in mm.

Type	Dimensions								Weight kg
	A mm	B mm	C mm	D mm	E mm	F mm	G mm	H mm	
JK-12 TS	850	460	400	5"		880	300	2255	78
JK-20 TS	1105	615	400	200	450	800	400	2525	89
JK-22 TS	1280	625	600	225	460	1070	300	2695	98
JK-25 TSD	2470	630	600	250	505	1100	300	2635	182



## Accessories

Rotary valve type JK-S/JK-EXS.....	Page 48
Rotary valve type B-S/B-EXS.....	Page 49
EXS.....	Page 50
Cast-iron rotary valve type JK-T.....	Page 51
Separator.....	Pages 52-53
Cutter.....	Page 54
Combination valve.....	Page 55
Filter medium.....	Pages 56-57
Cyclone type CS.....	Page 58
Cyclone type JA.....	Page 59
Big bag-solution.....	Page 60
Dust bucket.....	Page 61
Explosion duct valve.....	Page 62-63

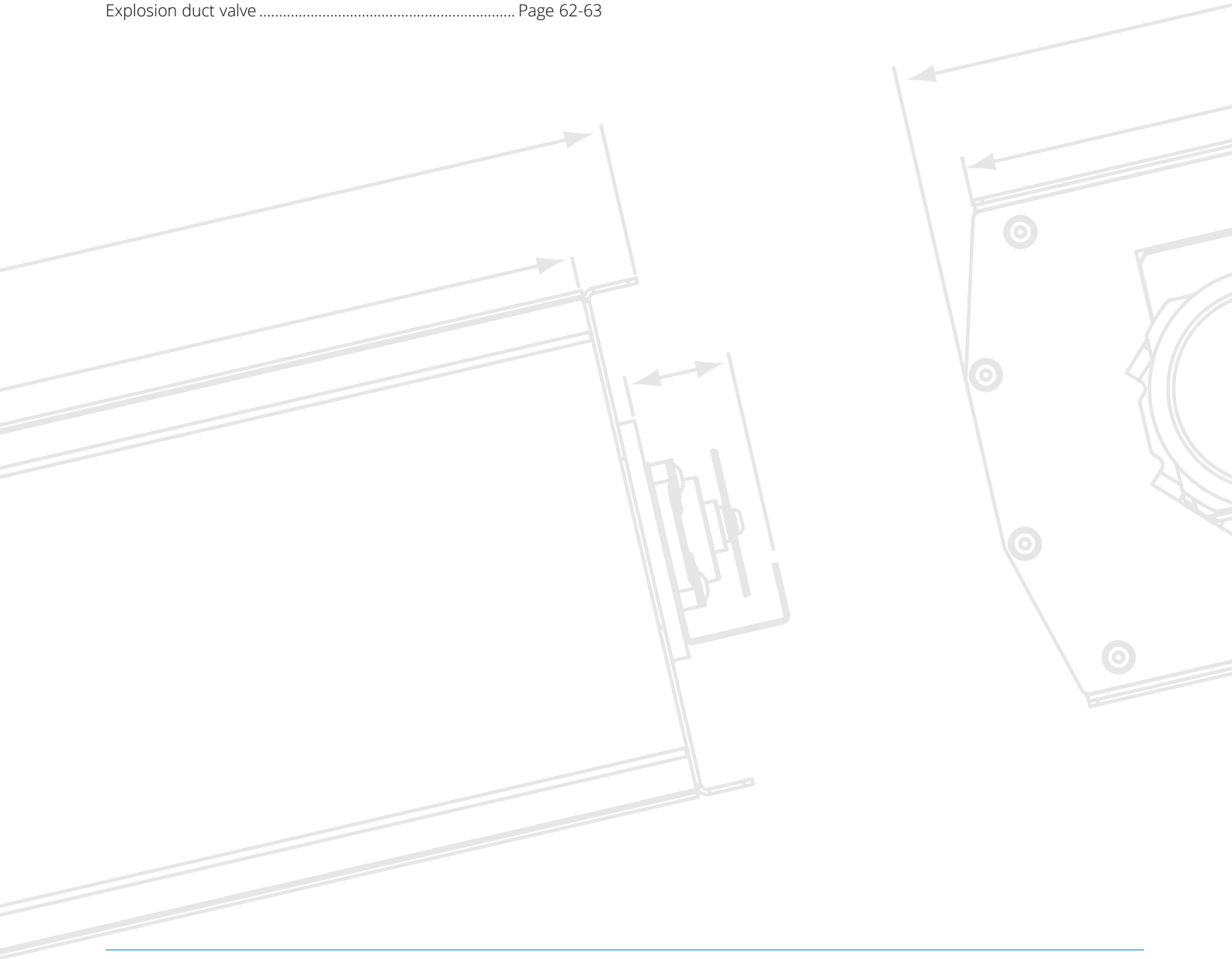

## Rotary valve type JK-S/JK-EXS

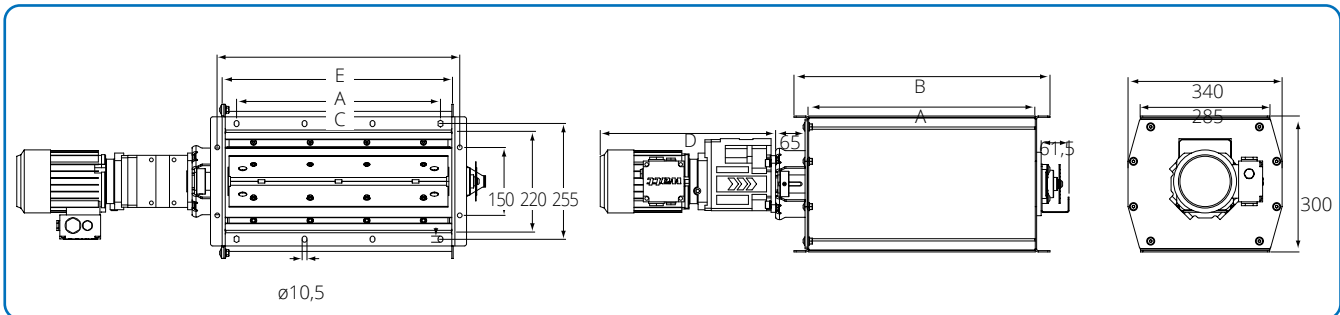

Dimensional specifications are given in the table below.

Rotary valves type JK-S/JK-EXS are fitted with a 6-bladed rotor with hard-wearing rubber blades bolted to the rotor shaft plate profiles.

The rotor is separated from the rotor housing by felt ring. The shaft is suspended on bearings and connected directly to the gear motor.

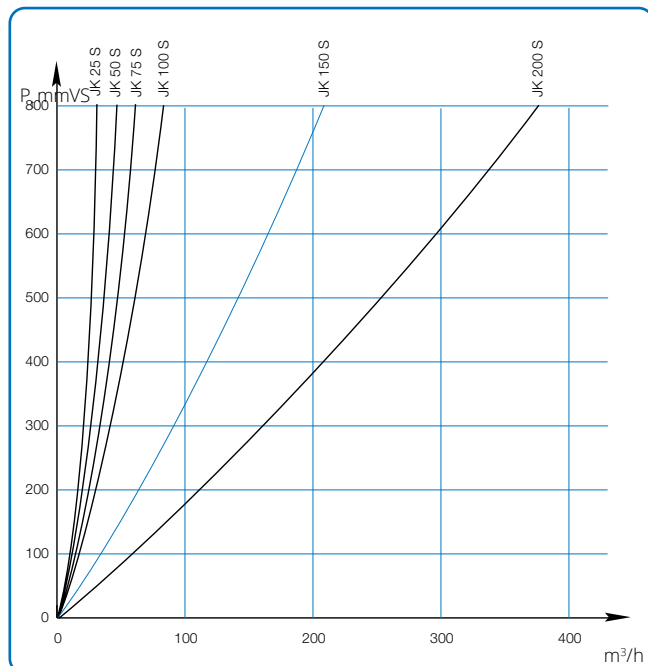

Diagram states loss through rotary valve depending on pressure conditions.

Type JK-200S is also fitted with a safety coupling between rotor and gear motor.

The rotor is made of 2 mm plate and can be supplied with a range of different rubber blades, e.g.:

- Neoprene rubber blades
- Silicone rubber blades
- Polyurethane rubber blades

JK-S rotary valve is ATEX-approved for category 2D, whereas JK-EXS is approved for category 1D safety system. The EXS variants are only available with rubber blades made of neoprene.

### Rotation sensor

Supplied as standard ready for fitting of rotation sensor.

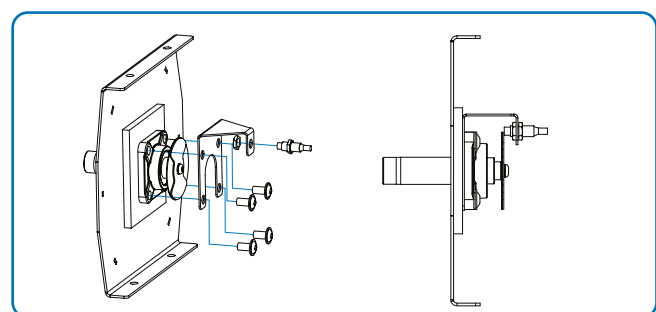

Rotation sensor

Dimensions						
Type	A mm	B mm	D mm	E mm	C mm	Weight kg
JK-25S	250	315	387	285	1 × 150	45
JK-50S	500	565	387	535	3 × 150	59
JK-75S	750	815	387	785	4 × 150	73
JK-100S	1000	1065	416	1035	6 × 150	94
JK-150S	1500	1565	416	1535	9 × 150	122
JK-200S	2000	2065	416	2035	13 × 150	165
JK-25EXS	250	315	387	285	1 × 150	47
JK-50EXS	500	565	387	535	3 × 150	60
JK-75EXS	750	815	387	785	4 × 150	73
JK-100EXS	1000	1065	416	1035	6 × 150	92

Rotor diameter = ø300 mm

Dimensions				
Type	Motor output kW	Ampere consumption at 400 V	Max min <sup>-1</sup>	Capacity 50% full m³/h
JK-25S/EXS	0,37	1,14	20	10
JK-50S/EXS	0,37	1,14	20	20
JK-50S/EXS	0,55	1,55	20	20
JK-75S/EXS	0,37	1,14	20	32
JK-75S/EXS	0,55	1,55	20	32
JK-100S/EXS	0,55	1,55	20	42
JK-150S	0,55	1,55	20	63
JK-200S	0,55	1,55	20	83

## Rotary valve type B-S/B-EXS

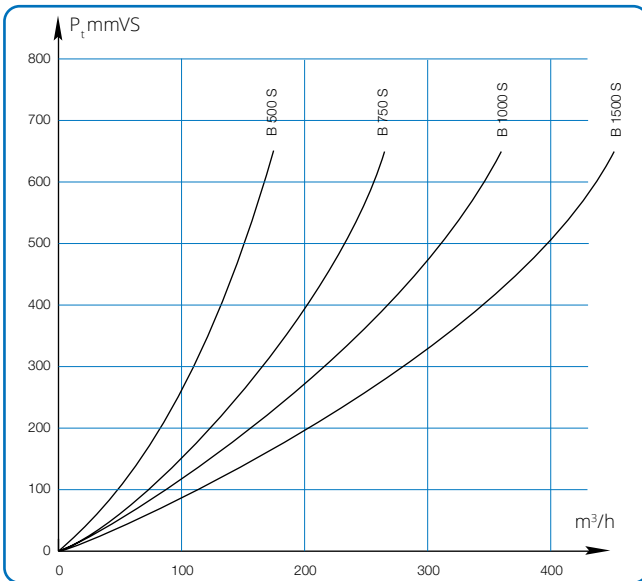
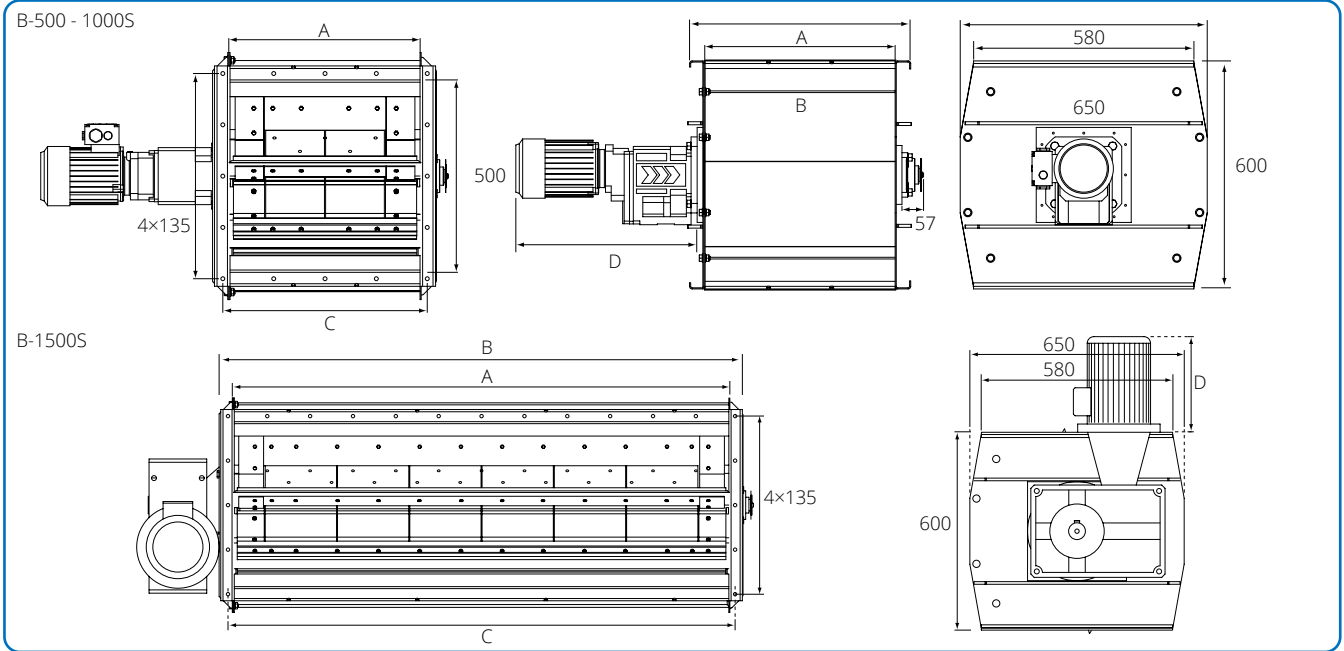

Diagram states loss through rotary valve depending on pressure conditions.

Rotary valves type B-S/B-EXS are fitted with an 8-bladed rotor with hard-wearing rubber blades bolted to the rotor shaft plate profiles.

The rotor is separated from the rotor housing by felt ring. The shaft is suspended on bearings and connected directly to the gear motor.

The rotor is made of 2 mm plate and can be supplied with a range of different rubber blades, e.g.:

- Neoprene rubber blades
- Silicone rubber blades
- Polyurethane rubber

B-S rotary valve is ATEX-approved for category 2D, whereas B-EXS rotary valve is ATEX-approved for category 1D safety system.

The EXS variants are only available with rubber blades made of neoprene.

Dimensions					
Type	A mm	B mm	D mm	C mm	Weight kg
B-500S	500	580	525	4 × 135	140
B-750S	750	830	525	5 × 158	185
B-1000S	1000	1080	610	8 × 130	260
B-1500S	1500	1580	296	12 × 130	480
B-500EXS	500	580	525	4 × 135	140
B-750EXS	750	830	525	5 × 158	185
B-1000EXS	1000	1080	610	8 × 130	260

Dimensions				
Type	Motor output kW	Ampere consumption at 400 V	min <sup>-1</sup>	Capacity 50% full m <sup>3</sup> /h
B-500S	0,75	1,82	16	60
B-750S	0,75	1,82	16	90
B-1000S	1,10	2,50	16	120
B-1500S	2,20	4,85	16	180

## EXS

JKF's EXS rotary valves may be used for zone 20, which is the dust-filled side of a filter. EXS rotary valves may also be used as a safety component as described in the ATEX Directive: *"- should an explosion nevertheless occur which could directly or indirectly endanger persons and, as the case may be, domestic animals or property, to halt it immediately and/ or to limit the range of explosion flames and explosion pressures to a sufficient level of safety."*

If there is hazard related to the ATEX-zone in the filter, a safety component must be used. For example, if explosion duct valves are installed in the installation, EXS rotary valves must be used.

As a JKF customer, the choice of control is free as long as the control meets the requirements specified in the user manual, which are:

- The rotary valves must stop 500 ms after the explosion occurs
- Compliance with the specifications of EN-15089

It should be noted that JKF does not manufacture or supply controls with the EXS rotary valves.

CE 1073 (Ex) II 1D/3D h(c) IIIB T120°C  
 D (Ex) (Protective system)  
 FSA 08 ATEX 1586X



**1 PRODUCTION QUALITY ASSURANCE NOTIFICATION**  
 Notification No.: DANCERT 21ATEX7443Q

**DANCERT**  
 DANISH TECHNOLOGICAL INSTITUTE  
 Dancert A/S  
 Grøngårdsvej 1  
 DK-2630 Taastrup  
 Phone +45 72202160  
 info@dancert.dk  
 www.dancert.dk  
 CVR no. DK-29512094

**2 Equipment or protective System intended for use in potentially explosive atmospheres Directive 2014/34/EU**

**3 Notification Number:** DANCERT 21ATEX7443Q

**4 List of products covered by this notification:**  
**Rotary Valves type: B-EXS and type JK-EKS in type of protection "h" covered by EC Type Examination Certificates FSA 08 ATEX 1586 and FSA 15 ATEX 1658X**

**5 Applicant - Manufacturer or Authorized Representative in the Community:**  
**JKF Industri A/S**  
 Rørsangervej 5  
 9560 Hadsund

**6 Manufacturing Location(s):**  
**JKF Industri A/S, Rørsangervej 5, 9560 Hadsund**

**7 Dancert A/S, Notified Body number 1073, for Annex IV in accordance with Article 21 of the Council Directive 2014/34/EU of 26 February 2014 notifies to the applicant that the manufacturer has a production quality system, which complies with Annex IV of the Directive.**  
 This quality system in compliance with Annex IV of the Directive also meets the requirements of Annex VII, "Conformity to Type Based on Product Quality Assurance".

**8 This notification is based on audit report No. DANCERT 21ATEX7443Q issued the 19-02-2021. This notification can be withdrawn if the manufacturer no longer satisfies the requirements of Annex IV. Results of periodical re-assessment of the quality system are a part of this notification.**

**9 This notification is valid until 23-04-2024 and can be withdrawn if the manufacturer does not satisfy the production quality assurance surveillance.**

**10 According to Article 16 (3) of the Directive 2014/34/EU the CE mark shall be followed by the identification number 1073 identifying the Notified Body involved in the production control stage.**  
 This notification may only be reproduced in its entirety and without any change.  
 The validity of the certificate can be verified at [www.dancert.com](http://www.dancert.com)  
 Valid as of: 23-04-2021

This PDF document is only valid if digitally signed by Dancert A/S



**(1) EC TYPE-EXAMINATION CERTIFICATE (Translation)**  
 (2) Directive 94/9/EC  
 Equipment intended for use in Potentially Explosive Atmospheres

**(3) No. FSA 15 ATEX 1658X**

**(4) Rotary valve type B-EXS and type JK-EKS**

company  **JKF Industri**  
 CLEAN AIR INNOVATION SINCE 1957

**(5) JKF Industri A/S**  
**(6) Rørsangervej 5**  
**DK-9560 Hadsund**

(7) The design of this device and protective system as well as the various approved versions are defined in the annex to this EC type-examination certificate.  
 (8) The notified body, FSA GmbH, EC identification number 0588, certifies that this device and protective system comply with the Essential Health and Safety Requirements relating to the design and construction of the device and the protective system for use in potentially explosive atmospheres given in Annex II of the Directive 94/9/EC.  
 The test results are documented in certification report no. G-15-08-06 Z.

(9) The essential health and safety requirements are met by compliance with:  
 EN 1127-1:2011, EN 13453-1:2009, EN 14469-2:2007, EN 17050-1:2007, EN 15089:2009

(10) If an "X" is given after the certificate number, attention is drawn to special conditions for the safe use of the device or the protective system in the annex to this certificate.  
 (11) This EC type-examination certificate relates only to the design and construction of the defined device and protective system. Further requirements in this directive apply to the manufacture and placing on the market of this device and protective system.  
 (12) The marking on the device and the protective system must contain the following information:

**(Ex) II 1D / 2D T125C (Device Inside/Outside)**  
**D (Protective system)**  
**FSA 15 ATEX 1658X**

 **Mannheim, 2<sup>nd</sup> of February 2015**

 Prof. Dr. S. Radandt  
 Head of notified body

 Sr. M. Kraß  
 Certifier

FSA GmbH  
 Dancertstr. 1-3  
 68153 Mannheim  
 Germany  
 Tel.: +49 (0) 621 4456-1555  
 Fax: +49 (0) 621 4456-1504  
 zert@fhs.de

Page: 1 of 2  
 This certificate may only be reproduced in its entirety and without change

## Cast-iron rotary valve type JK-T

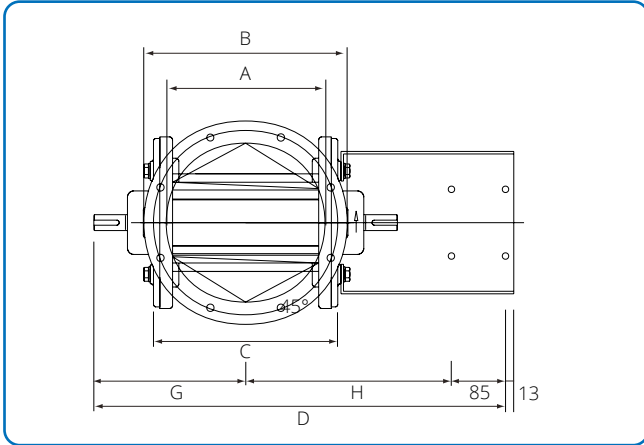

Dimensional specifications are given in the table below.

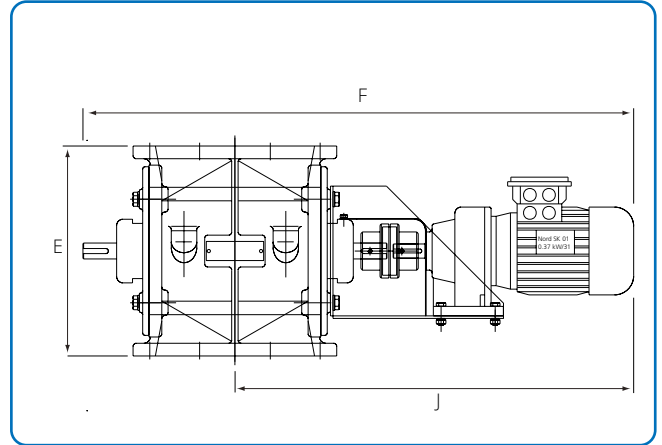

Dimensional specifications are given in the table below.

Type JK-T cast-iron rotary valves are designed for material emptying under difficult physical conditions. The rotary valves remain sealed up to a pressure of 500 mmVS and can work in temperatures right up to 250°C if equipped with special bearings.

Housing and its end plates are cast-iron, whilst the robust rotor is steel. The rotor is also available in stainless steel.

The JK-T rotary valve is supplied as standard with nylon or vulkolan rotor blades depending on requirement.

Rotary valves are supplied painted as standard. They are also available with chrome plating on the internal surfaces of the housing and covers. This version is ideal for separation of abrasive materials.

Alternatively, the rotary valve range can be fitted with an 8 chamber rotor to achieve better integrity. In this version, they are sealed right up to 4000 mmVS.

JK-T rotary valves are available in a range of different configurations.

Dimensions										
Type	A mm	B mm	C mm	D mm	E mm	F mm	G mm	H mm	J mm	Weight kg
JK-T250	250	320	290	661	330	855	239	324	616	120
JK-T350	350	420	390	767	400	963	295	374	668	145

Dimensions					
Type	Motor	Motor output kW	Ampere consumption at 400 V	min <sup>-1</sup>	Capacity at 50% full m <sup>3</sup> /h
JK-T250	IP 55	0.37	0.94	32	8.75
JK-T350	IP 55	0.37	0.94	33	27.75

## Separator type JK-PS

Type JK-PS separators are designed to separate solids from carrier air in over- or under-pressure systems.

The separator design ensures low pressure loss and unpressurised material separation, making it possible to install the separator directly connected to other equipment, such as compressors and containers.

They are able to separate particles greater than 3 mm, but the max. size is governed by the dimensions of the rotor chamber.

Rotor blades are fitted with vulkolan rubber blades to ensure a seal between rotor and rotor housing.

Operating temperature max. +60°C and min. -10°C

Rotor RPM = 18 min<sup>-1</sup>

The capacities stated are values from tests with mixed cardboard, paper and corrugated cardboard weighing 40 kg/m<sup>3</sup>.

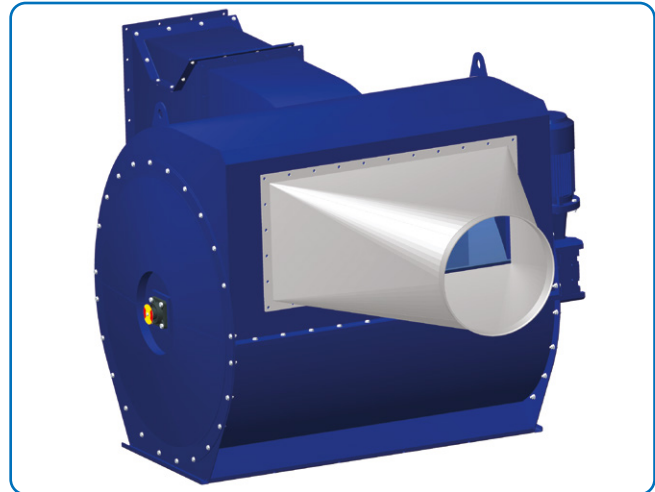

Type	Dimensions			Max. pressure mmVS	kW	Ampere consumption at 400 V	Weight kg
	Capacity m <sup>3</sup> /h	Capacity kg/h	min <sup>-1</sup>				
JK-5PS	5000	700	16	800	1.5	3.35	242
JK-10PS	10000	1200	16	800	2.2	4.55	410
JK-20PS	20000	2500	17	650	4.0	8.40	814

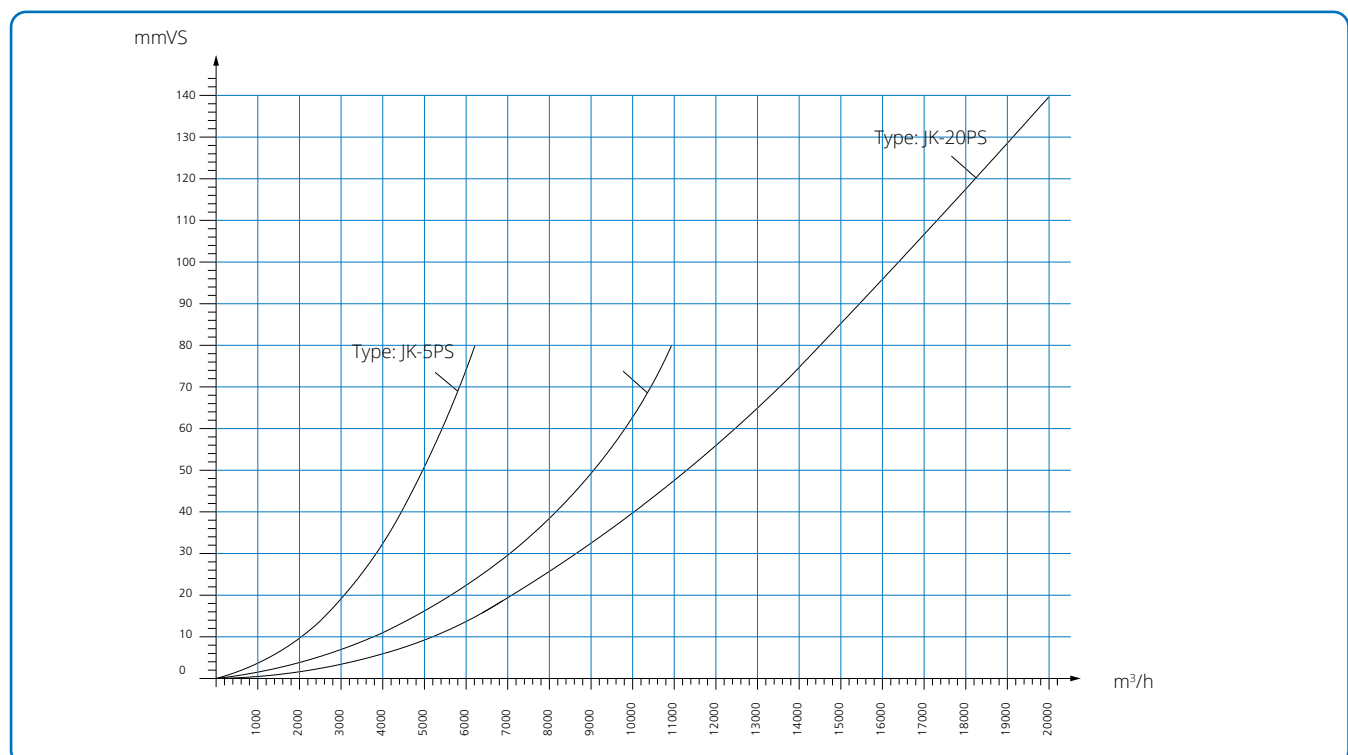

Pressure loss curves depend on air volume.

## Separator

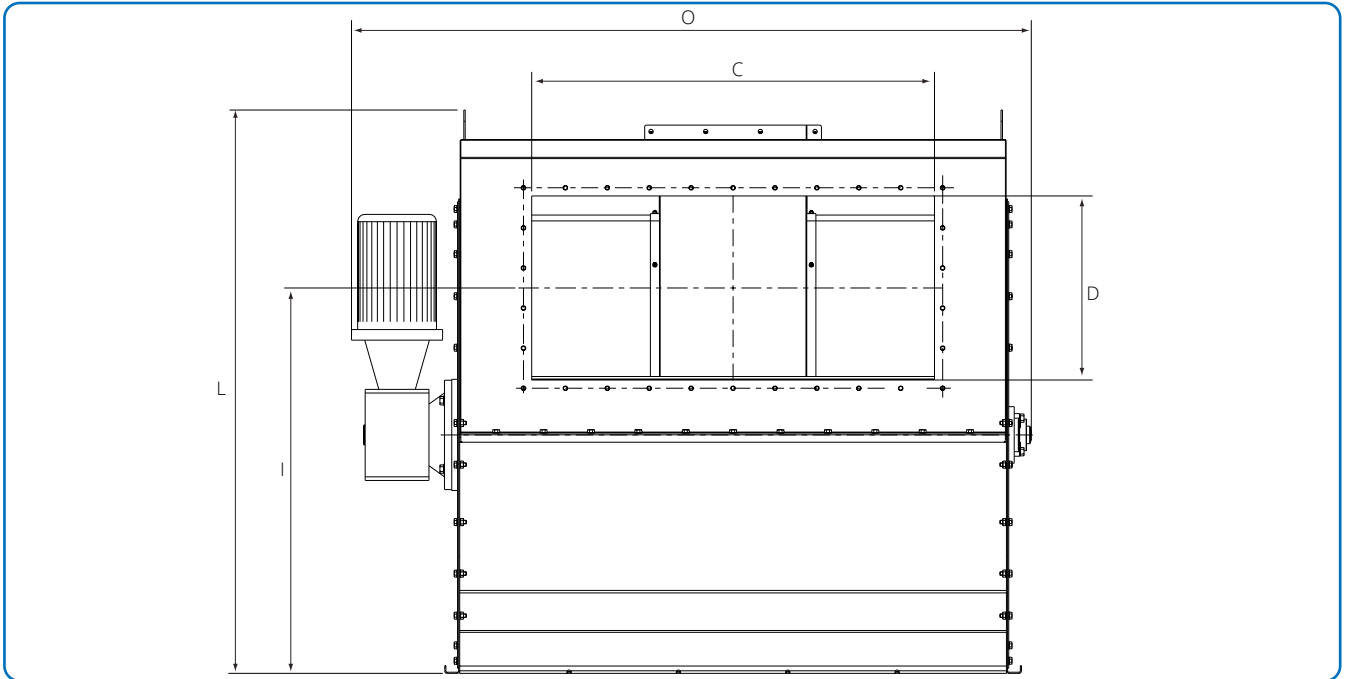

Dimensional specifications for lengths are given in the table below.

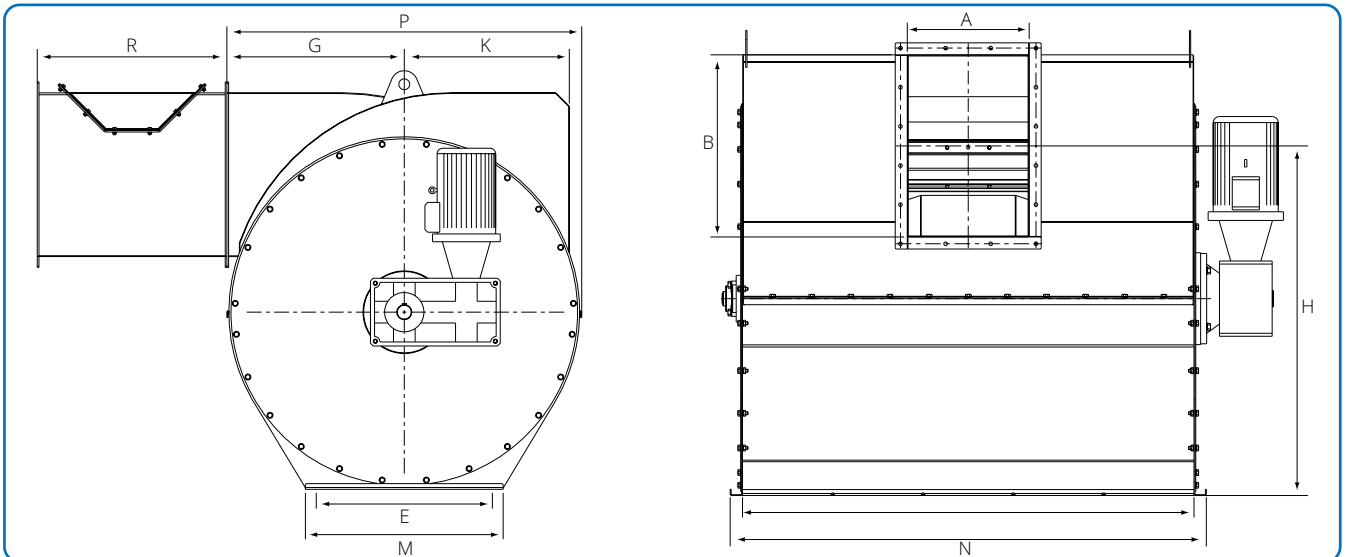

Dimensional specifications for lengths are given in the table below.

### Dimensions

Type	A mm	B mm	C mm	D mm	E mm	F mm	G mm	H mm	I mm	K mm	L mm	M mm	N mm	O mm	P mm	R mm
JK-5PS	220	320	600	300	500	750	351	665	630	311	875	586	836	1072	712	500
JK-10PS	220	500	750	400	500	1000	457	814	809	411	1120	580	1082	1372	914	600
JK-20PS	400	600	1100	500	650	1500	655	1162	1057	609	1544	730	1582	1884	1310	700

## Cutter

Type JK-2 JC and JK-3 JC cutters are designed for continuous cutting of plastic and paper strips in cut or endless rolls from edge cutters and roller cutter machines.

The cutter chops strips into small pieces, which are easier to transport than long strips, ensuring smooth transport to a collection point or processing.

Consists of one fixed and one rotating set of blades driven by a direct drive motor. The blades are made of a specially-hardened steel which is highly durable with very long service life. Apart from adjustment and grinding, the blades require no maintenance.

The cutter is fitted in a pipe system either connected to paper or print machines, extruders or processing machines.

It can be integrated directly into any pipe system between  $\varnothing 150$  and  $\varnothing 200$  mm.

JKF's standard assembly methods are used for joining to a pipe system.

### Specifications

Rotor with angled blades:

Type JK-2 JC: 2 x blades

Type JK-3 JC: 3 x blades

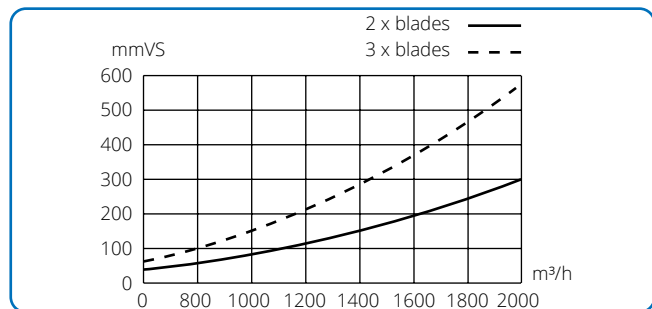

Noise level:	Less than 80 dBA		
Motor type:	KPER 80 K2 B5 IP55	KPER 80 G4 B5 IP55	KPER 80 G6 B5 IP55
Output:	0.75 kW	0.75 kW	0.75 kW
Speed:	2800 min <sup>-1</sup>	1380 min <sup>-1</sup>	920 min <sup>-1</sup>
Weight incl. motor:	30 kg	31 kg	31.8 kg
Nom. amp. consumption:	1.72 A	2.10 A	1.73 A
Power supply:	3 x 400 V, 50 Hz		
Start:	Manual/direct		

### Limitations:

- Max. air volume 1600-1800 m³/h
- Paper, cardboard up to 600g/m²
- Plastic up to 0.6 mm

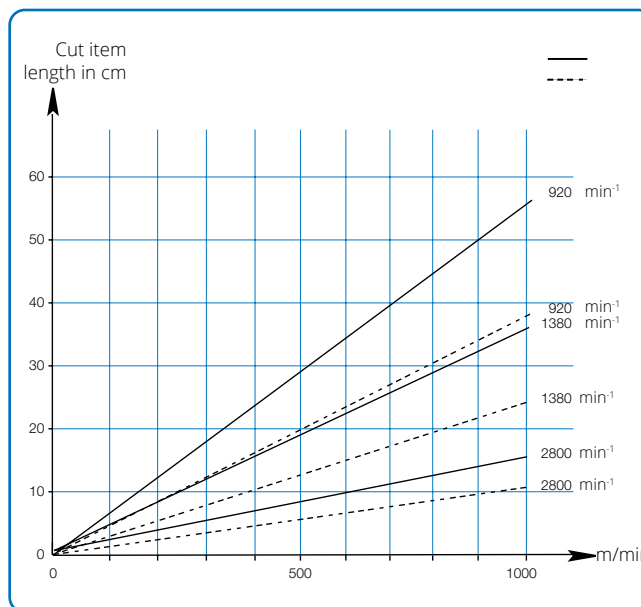
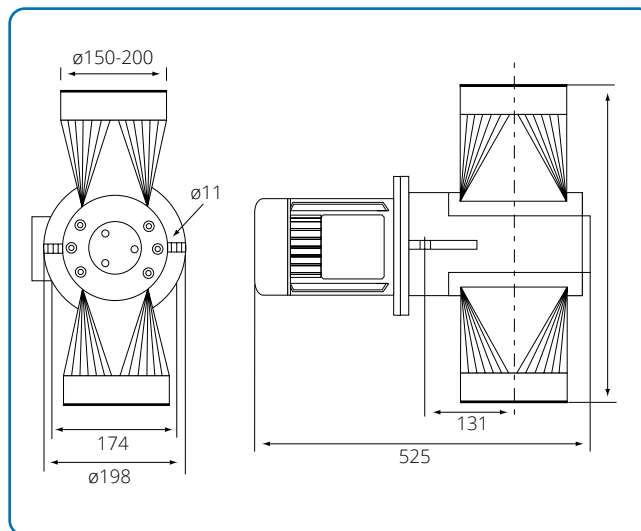

Cut item length is achieved by selection of cutter type with 2 or 3 blades and choice of motor speed. Strip speed must be known. Cut item length can vary. The lengths stated are examples. Please refer to technical data in the preceding column.



## Combination valve

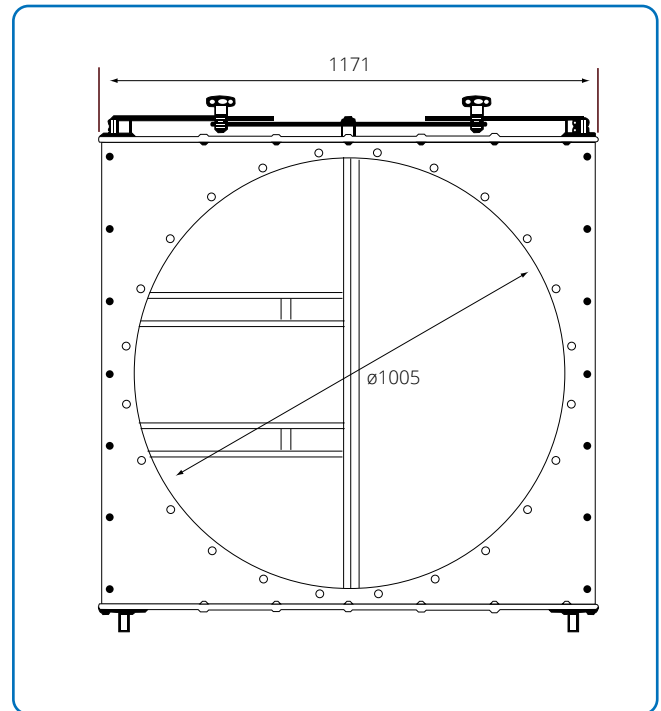
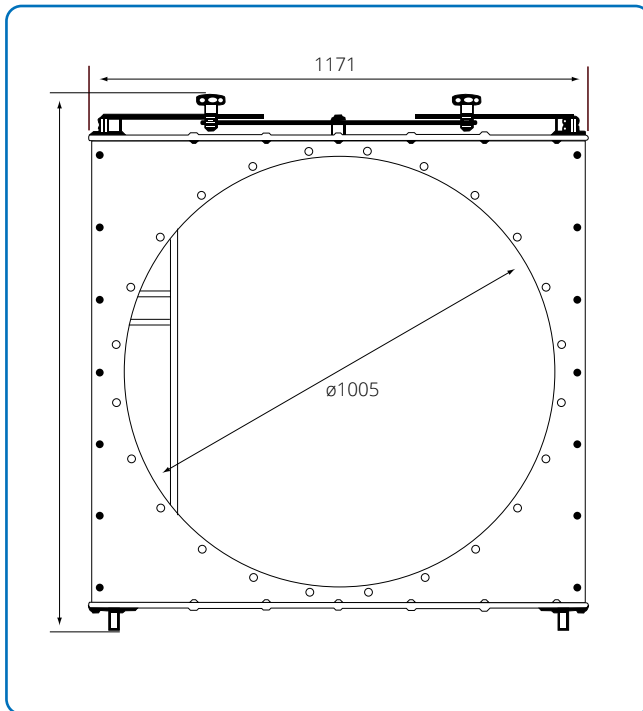

*Dimensional specifications are given in the table.*

Combination valve helps reduce extraction plant energy consumption. The valve is fitted after the filter clean air discharge. Return air from the filter can either be fed back to the production area or outdoors via the combination valve.

NB! Not all countries permit direct return of all extracted air to production areas.

The heavy duty design of the valve ensures stable operation even for the largest air flows. The valve flaps are specially-reinforced for precise and stable operation. The valves are fitted with 2 x 1000 mm diameter 45° bars and bird netting. A special type is available to cover a range from 30,000 to 60,000 m<sup>3</sup>/h.

ø1000 mm flange connector is standard. Transition sleeves or adapters are required for other pipe dimensions.

Dimensions	
Pipe dimension ø mm	Air volume m <sup>3</sup> /h
710	30,000
800	38,000
900	48,000
1000	55,000
1120	60,000
1250	65,000

## Filter media



JKF can supply filters for most industry sectors where manufacturing processes generate dust, chips and dirt to be extracted and filtered. Examples:

- Woodworking
- Iron and metal industries
- Surface treatment
- Sandblasting
- Corn, seed and feeds
- Cement and concrete
- Power generation
- Insulation manufacturing
- Packaging manufacturing
- Recycling industries

### Energy-saving and environment-friendly filter element/pleated filter bag

Filter element consists of polyurethane bottom and top, integral polypropylene support pipe embedded at both ends. The pleated filter medium is on the outside.

The external geometry is largely uniform as are the self-locking fixtures.

The filter elements are available in two basic models with different fold heights in integral support pipes:

1. 16 mm fold height int. support pipe  $\phi 127/\phi 117$
2. 24 mm fold height, int. support pipe  $\phi 110/\phi 104$

The filter medium is cotton or polyester, which can be coated with a range of finishes: antistatic, PTFE (Teflon-coated), antistatic and PTFE (Teflon-coated), Teflon membrane.

Polyester can be washed up to 4 times.

The filter elements are also available with - micromelt, which is extremely permeable but with a filtration degree of 99.98%.

Micromelt is non-washable.

- cellulose-coated paper, NA 138 FH, with large surface area. Non-washable.

### Pleated bags, offering the following benefits:

- very low pressure loss thanks to optimal geometry.
- 2-3 times more filter area than conventional filter bags.
- self-locking flange makes replacement easy.
- long service life - pleated bags can be washed up to 4 times.
- made of environment-friendly materials.
- used filter elements can be sent for incineration.

### Filter bags

Polyester filter media with a range of coatings.

Standards: Polyester PE40/PP25 or PE40/PP25 antistatic.

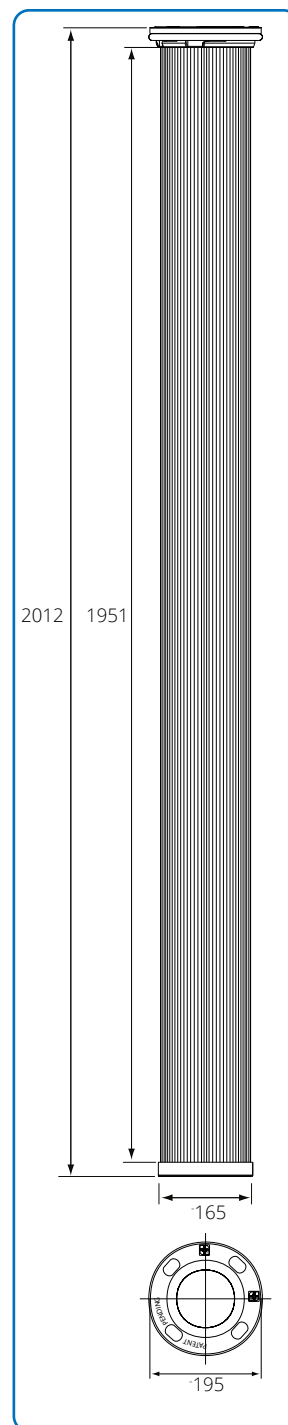

Designation	Area m <sup>2</sup>	Length mm	Weight kg	Dimensions						
				Paper	Plastic	Powder coating	Sanded	Sand-blasting	Welding fumes	Plasma/laser fumes
NA-909	5.81	2000	3.70						x	
NA-909	7.12	2000	3.90						x	
NA-909 Antistatic	5.81	2000	3.70	x	x	x				
NA-909 Antistatic	7.12	2000	3.90	x	x	x				
NA-909 PTFE	5.81	2000	3.70			x	x			x
NA-909 PTFE	7.12	2000	3.90			x	x			x
NA-909 Antistatic+PTFE	5.81	2000	3.70			x	x			x
NA-909 Antistatic+PTFE	7.12	2000	3.90			x	x			x
NA-800 Membrane	5.81	2000	3.70							x
NA-800 Membrane	7.12	2000	3.90							x
NA-220 Micromelt	3.97	1385	3.20						x	x
NA-220 Micromelt	4.87	1385	3.40						x	x
NA-909	3.87	2000	4.00	x					x	
NA-909	4.74	2000	4.20	x					x	
NA-909 Antistatic	3.87	2000	4.00	x	x	x	x			
NA-909 Antistatic	4.74	2000	4.20	x	x	x	x			
NA-909 PTFE	3.87	2000	4.00			x	x		x	
NA-909 PTFE	4.74	2000	4.20			x	x		x	
NA-909 Antistatic+PTFE	3.87	2000	4.00		x	x	x		x	
NA-909 Antistatic+PTFE	4.74	2000	4.20		x	x	x		x	
NA-800 Membrane	3.87	2000	4.00							x
NA-800 Membrane	4.74	2000	4.20							x
NA-220 Micromelt	2.69	1385	3.20						x	x
NA-220 Micromelt	3.25	1385	3.40						x	x
NA-138FH, Cellulose	12.60	1385	2.40						x	x
NA-138FH, Cellulose	15.20	1385	3.72						x	x

Type	Diameter mm
PE40/PP25	ø150, ø220, ø400, ø600
PE40/PP25 Antistatic	ø150, ø220, ø400, ø600
PE40/PP25 Anti+Antifin	ø150, ø220
PE45/PE15 BIA G	ø150, ø220
PE50/PE16	ø150, ø220, ø400, ø600
PE50/PE16 Antistatic	ø150, ø220, ø400, ø600

## Cyclone type CS

Spiral cyclones type CS are used for air treatment plants in the wood and paper industries and for corn and feed to separate chaff and corn dust in exhaust air from drying and cleaning plants.

They are made of rolled and riveted hot-dip galvanised sheet metal, but can be supplied in welded 2 - 3 mm sheet.

Type CS-20 is painted in RAL 5010.

Cleaning door in cone is an optional extra.

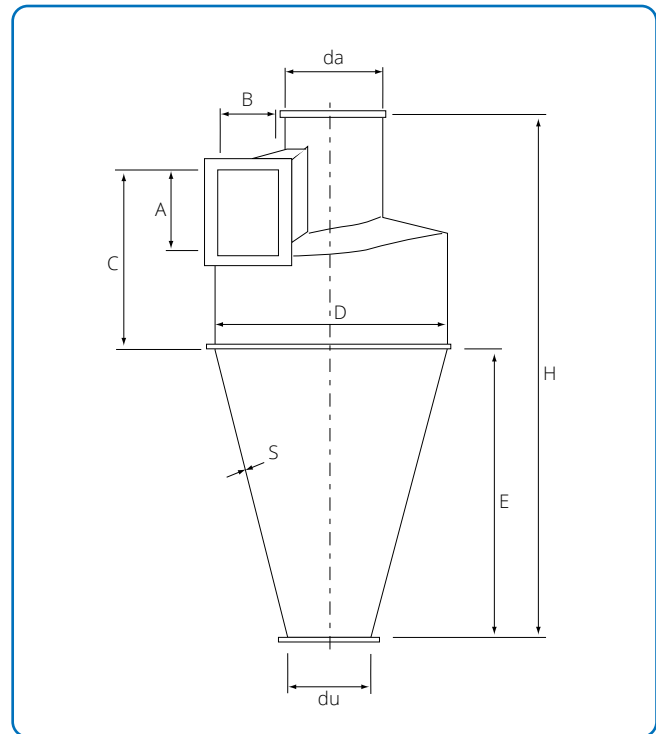
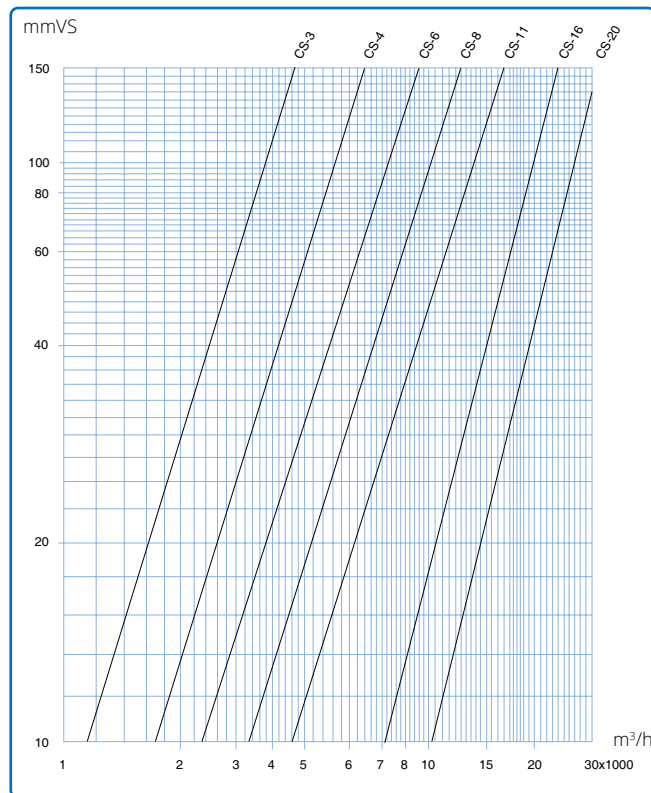

Dimensional specifications for lengths are given in the table below. Cleaning door is optional extra.

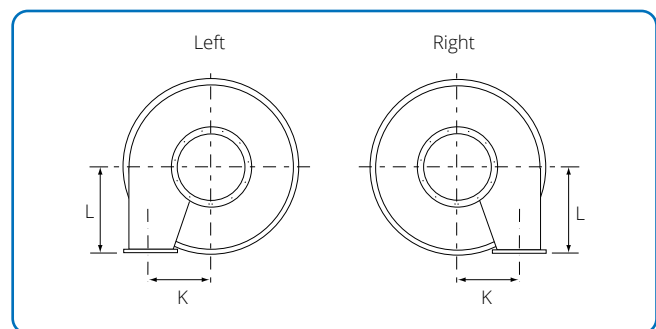

Dimensional specifications for lengths are given in the table below.

Type	Dimensions											Weight kg
	A mm	B mm	C mm	D mm	da mm	du mm	E mm	H mm	S mm	K mm	L mm	
CS-3	300	200	640	800	350	200	1150	1980	0.9	300	420	50
CS-4	350	250	740	950	400	200	1330	2280	0.9	350	500	65
CS-6	400	300	840	1100	450	250	1500	2580	0.9	400	580	80
CS-8	450	350	950	1300	500	250	1700	2930	0.9	475	675	120
CS-11	530	400	1130	1550	600	300	1900	3310	0.9	575	790	170
CS-16	640	480	1350	1850	750	300	1900	3600	0.9	685	970	210
CS-20	800	500	1410	2014	1000	400	1700	3450	2.00	757	980	360

## Cyclone type JA

Cyclone type JA is intended for separation of fine grain particles in transport and dust extraction plants.

Cyclones are designed for high efficiency.

Powder coating corrosion class C3.

Legs are non-standard, but available as optional extras.

Cleaning door in cone is an optional extra.

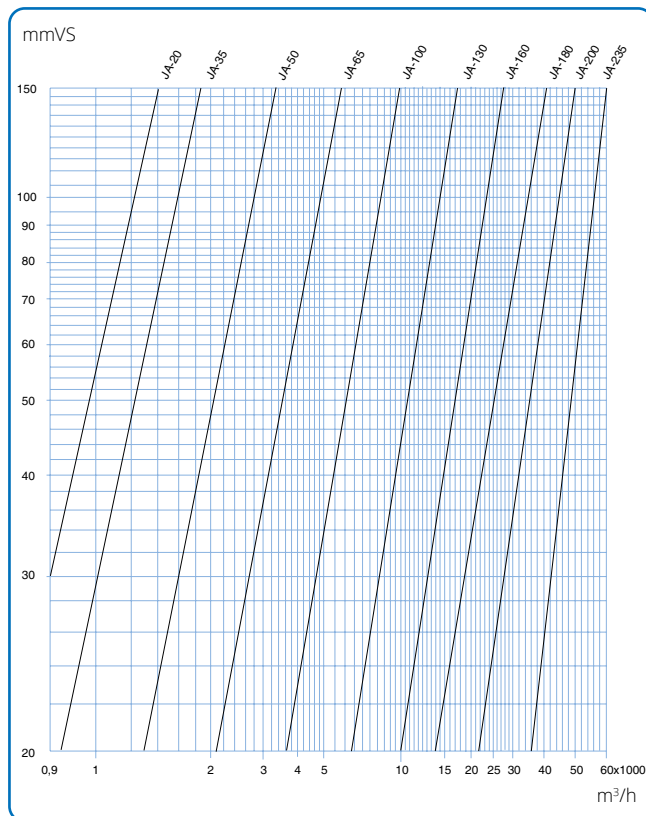
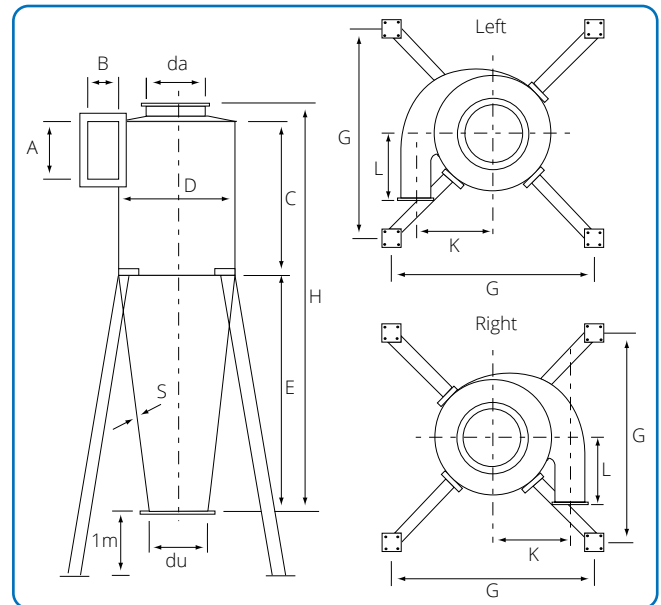
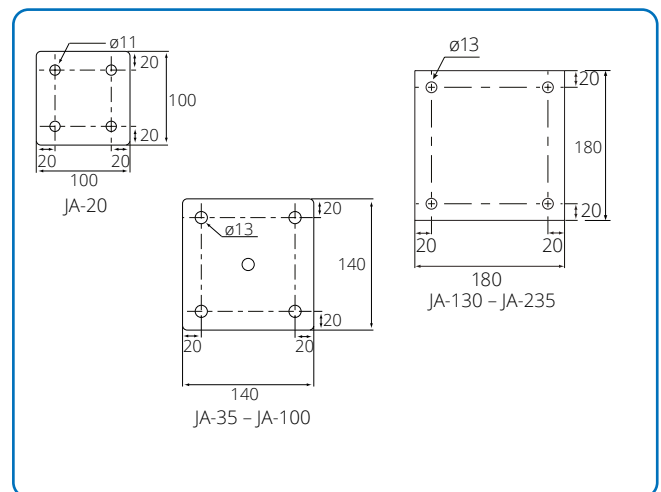

Diagram states pressure loss in cyclone at a given air volume measured in m<sup>3</sup>/h.



Dimensional specifications for lengths are given in the table below. Legs are optional extras.



Base plate

Type	Dimensions												Weight kg
	A mm	B mm	C mm	D mm	da mm	du mm	E mm	G mm	H mm	S mm	K mm	L mm	
JA-20	230	100	570	400	225	160	820	1050	1465	2	240	240	41
JA-35	285	125	710	500	250	200	1020	1200	1790	2	297	300	55
JA-50	350	160	710	500	250	200	1020	1200	1790	2	310	300	61
JA-65	445	200	995	700	400	300	1405	1539	2500	2	419	420	115
JA-100	560	300	1500	1000	550	400	2050	1960	3752	2	615	600	244
JA-130	750	400	2000	1280	700	450	2820	2305	5090	3	789	700	565
JA-160	1100	500	2000	1600	800	550	3150	2690	5420	3	1050	900	835
JA-180	1500	500	2500	1800	1000	650	3450	2790	6250	3	1157	950	1135
JA-200	1310	700	2800	2000	1250	800	4100	3400	7100	3	1310	1100	1415
JA-235	1850	800	3350	2350	1500	950	4860	3440	8500	3	1440	1200	2060

## Big bag-solution

The big-bag solution is a complete solution with a big-bag rack, rotor valve, screw conveyor and the connection to the individual filters.

It is provided with filling stub with protection against unintended access to rotating parts.

The big bag can either hang freely in the removable beams or be placed on pallets. In this way flexibility is achieved towards the behavior of various materials during filling of the big bag.

The rack can be mounted in 90° interval, at which the access can be tailored to the individual installation.

It is supplied with adjustable feet with anchor ring.

Rotary valve JK-25S/EXS, 0,37 kW, 230/400 V, 20 min<sup>-1</sup>  
 $I_N=1,14$  A

Screw conveyor JK-200SC, 0,55 kW, 230/400 V, 20 min<sup>-1</sup>  
 $I_N=1,55$  A

The rack is intended for a SWL of 1250 kg

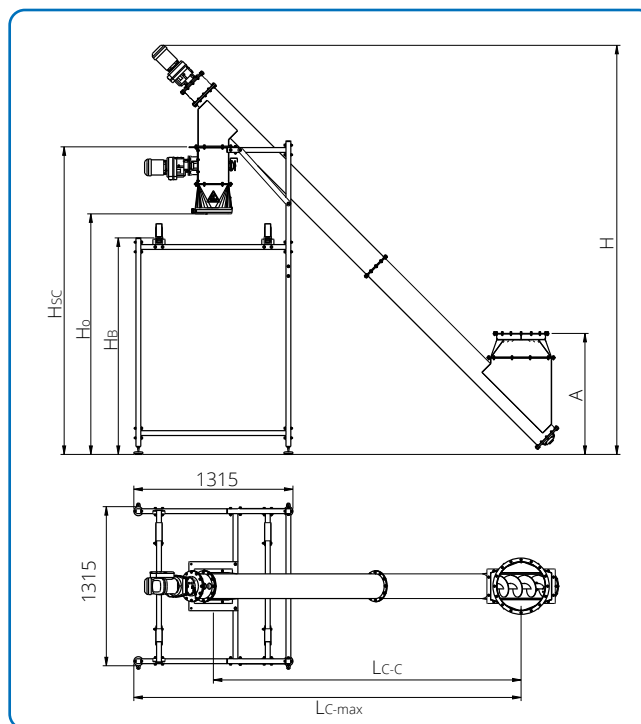

Item no.	Filter	H <sub>sc</sub> [mm]	H <sub>o</sub> [mm]	H <sub>b</sub> [mm]	H [mm]	A [mm]	L <sub>c-c</sub> [mm]	L <sub>c-max</sub> [mm]
2919010	DS-12-20S BF-20S	2332	1879	1679	2983	1000	3229	3886
2919020	DS-7-44K BF-8-90K	2356	1903	1703	3007	1000	3234	3891
2919030	MMBF raised 150 mm	2542	1988	1789	3412	800	2543	3201
2919040	SBF-K	2542	1988	1789	3412	850	2543	3201
2919050	DS-28-44S	2542	1988	1789	3412	1000	2543	3201
2919060	DS-12-44K BF-20-90K	2542	1988	1789	3412	1000	2543	3201
2919070	SBF-S BF-36-90S	2742	2088	1889	3612	1000	2543	3201
2919080	SJF	2742	2088	1889	3612	1100	2543	3201
83500114	Big bag w/stub 91 x 91 x 114 cm; 1000 kg							

## Dust bucket

The dust bucket is suitable for all Blower, EC and DustStorm filters with the exception of DS-7.

The dust bucket is mobile and ergonomic correctly designed. The handle can be locked in 2 positions. When the handle is locked in the upper position, the tank can easily be moved. When the handle is locked in the lower position, the tank is easily turned upside down for emptying.

Mounting of the bag can easily and quickly be carried out and without any risk that the bag subsequently will be lifted due to false air or vacuum inside the filter.

### Properties

Available with or without manual sliding damper in galvanised version.

The sliding damper is available with optional extras with an opening of  $\varnothing 300$  mm. Without the sliding damper the opening is  $\varnothing 400$  mm. A level gauge can be assembled as optional extras on both the solutions.

### Volume

Max. volume pos.	517 mm	65 litre
Volume for level switch pos.	294 mm	*37 litre

\*) The volume and the level of the material can be higher, because the dust can accumulate a top whereas the level switch only detects when it comes into contact with the material.

### Weight

Net weight 26 kg

Gross weight max. 226 kg

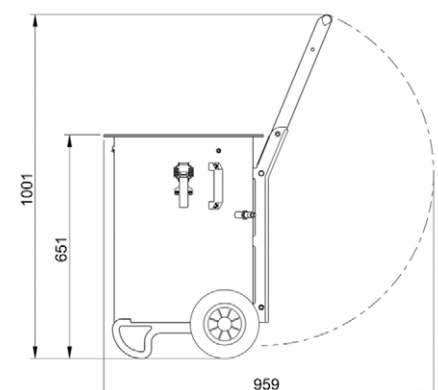
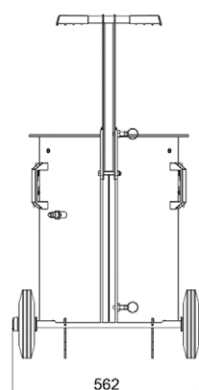
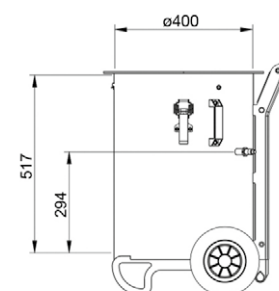
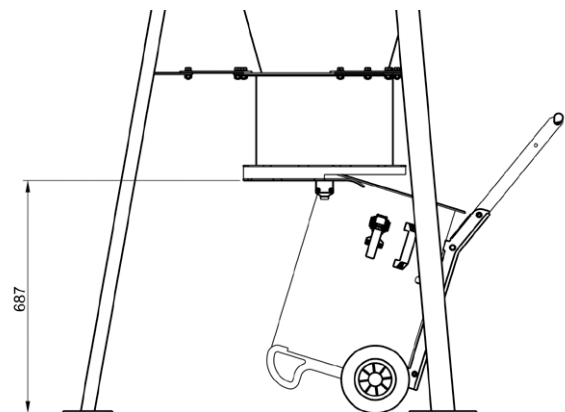
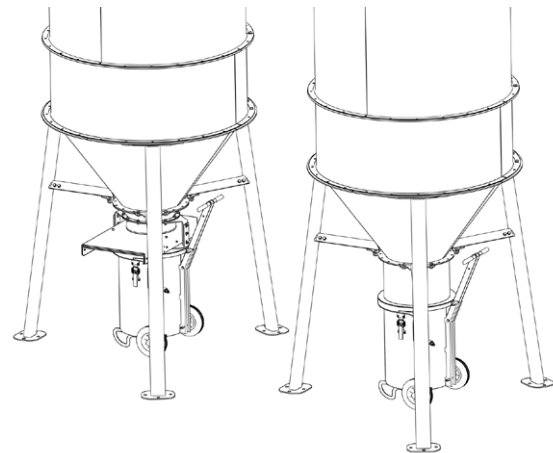

## Explosion duct valve

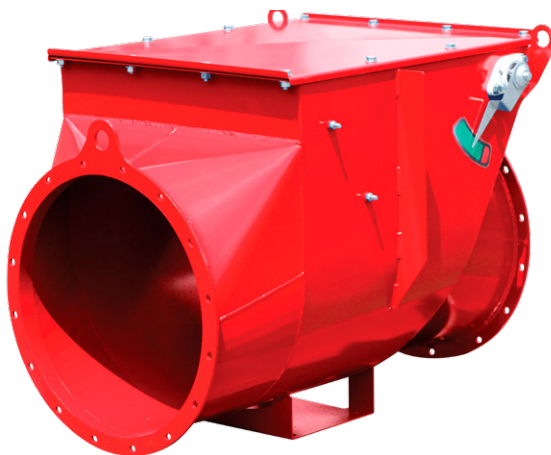

The explosion duct valve is used in order to prevent that an explosion in the plant will be channelled back to the production premises and machines. The explosion duct valve is mounted on the duct section between the plant and the dust source. The explosion duct valve stops explosions that occur in both flow directions of the normal flow. This means that the explosion duct valve can be mounted on both the inlet side and the outlet side on the dust separator. The dust separator covers filters, silos and industrial exhausters which are already protected with explosion relief or explosion suppression system.

It is delivered with position switch. The explosion duct valve is painted in RAL 3020.

Tested og approved:

- Dust explosion class St. 1
- EN 16447: 2014 - Explosion insulation systems
- EN 14460: 2018 Explosion resistant equipment
- EN 1127-1: 2019 Explosion prevention and protection - Part 1
- 2014/34/EU ATEX regulation

Certifications:

- ISO9001: 2015 Quality management

### Dimensions & installation distance

DN (mm)	DN (inch)	Minimum Vessel Volume	LMin* min. mounting distance	LMin+2m** min. mounting distance
160	6"	0,70 m <sup>3</sup>	4,0m	6,0m
160	6"	1,35 m <sup>3</sup>	3,0m	5,0m
180	7"	0,70 m <sup>3</sup>	4,0m	6,0m
180	7"	1,35 m <sup>3</sup>	3,0m	5,0m
200	8"	1,35 m <sup>3</sup>	4,6m	6,6m
250	10"	1,35 m <sup>3</sup>	4,0m	6,0m
300	12"	2,90 m <sup>3</sup>	4,6m	6,6m
350	14"	2,90 m <sup>3</sup>	4,2m	6,2m
400	16"	4,50 m <sup>3</sup>	5,2m	7,2m
450	18"	4,50 m <sup>3</sup>	4,7m	6,7m
500	20"	6,05 m <sup>3</sup>	5,8m	7,8m
550	22"	6,05 m <sup>3</sup>	5,5m	7,5m
600	24"	7,65 m <sup>3</sup>	7,2m	9,2m
650	26"	7,65 m <sup>3</sup>	6,7m	8,7m
700	28"	7,65 m <sup>3</sup>	6,4m	8,4m
750	30"	10,00 m <sup>3</sup>	7,3m	9,3m
800	32"	10,00 m <sup>3</sup>	6,9m	8,9m

\* Floating in horizontal position: Flap valve activated by the working air flow

\*\* Vertical position / With elbows / Flap valve kept open by its spring blade system.



## Explosion duct valve

### > Product process flow

**1** Flap is held open by process flow

Installation with floating flap

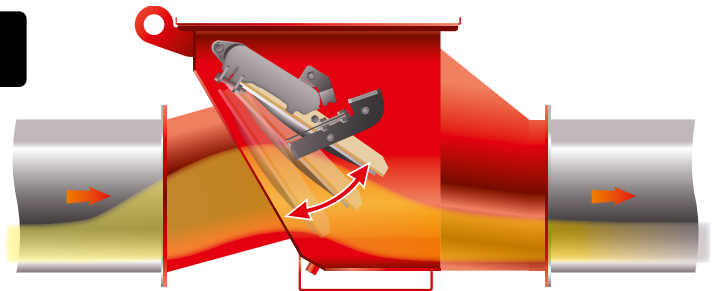

**2** Flap locked in open position

Installation with flap locked open

Locked open flap for dirty airside

OR

Locked open flap for clean airside

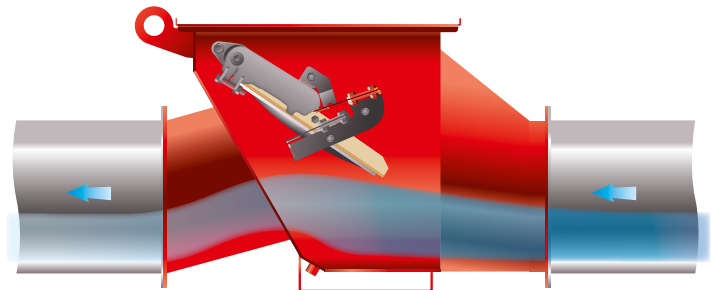
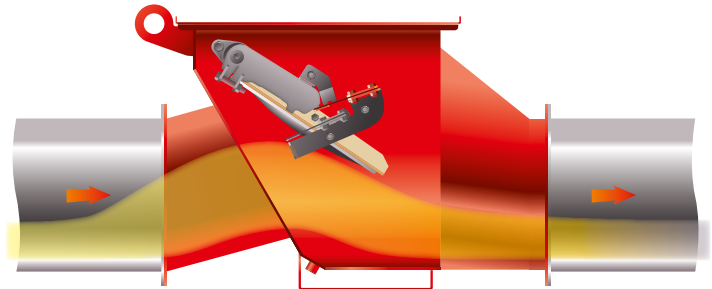

### > During an explosion event

Flap is closed by the explosion pressure wave and locked in place. Manual locking mechanism reset is required

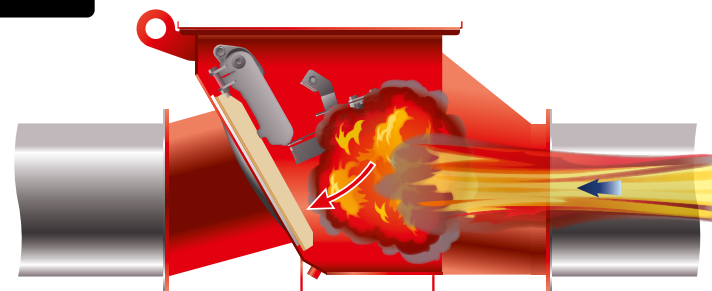



## THE WAY TO CLEAN AIR



### **JKF Industri A/S**

Rørsangervej 5, Als  
9560 Hadsund  
Denmark  
Tel: +45 98 58 12 11  
info@neujkf.dk  
www.jkf.dk

### **NEU-JKF Sp. z o.o.**

Berzyna 82,  
64-200 Wolsztyn  
Polska  
Tel: +48 68 347 07 00  
info@neu-jkf.pl  
www.neu-jkf.pl

### **NEU JKF Asia Sdn. Bhd.**

Lot 8521, Persiaran Industri Galla  
Galla Industrial Park, 70200 Seremban  
Negeri Seremban, Malaysia  
Tel: +606 764 9861  
info@neujkf.asia  
www.neujkf.asia