

## Cutter

Type JK-2 JC and JK-3 JC cutters are designed for continuous cutting of plastic and paper strips in cut or endless rolls from edge cutters and roller cutter machines.

The cutter chops strips into small pieces, which are easier to transport than long strips, ensuring smooth transport to a collection point or processing.

Consists of one fixed and one rotating set of blades driven by a direct drive motor. The blades are made of a specially-hardened steel which is highly durable with very long service life. Apart from adjustment and grinding, the blades require no maintenance.

The cutter is fitted in a pipe system either connected to paper or print machines, extruders or processing machines.

It can be integrated directly into any pipe system between  $\varnothing 150$  and  $\varnothing 200$  mm.

JKF's standard assembly methods are used for joining to a pipe system.

### Specifications

Rotor with angled blades:

Type JK-2 JC: 2 x blades

Type JK-3 JC: 3 x blades

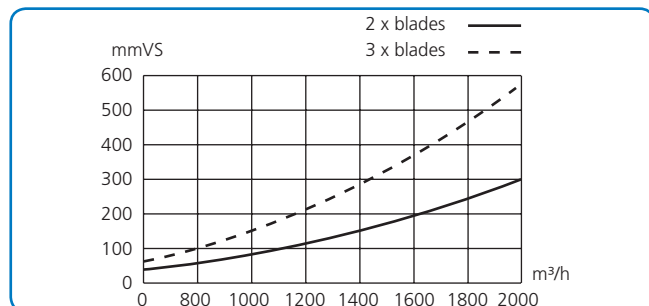
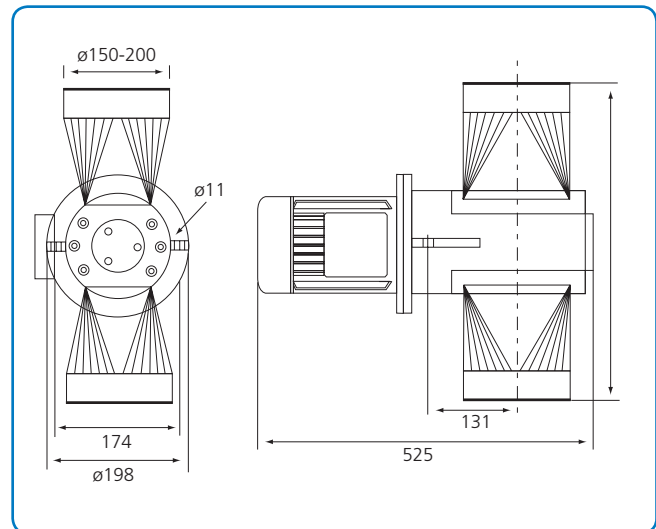

Noise level:	Less than 80 dBA		
Motor type:	KPER 80 K2 B5 IP55	KPER 80 G4 B5 IP55	KPER 80 G6 B5 IP55
Output:	0.75 kW	0.75 kW	0.75 kW
Speed:	2800 min <sup>-1</sup>	1380 min <sup>-1</sup>	920 min <sup>-1</sup>
Weight incl. motor:	30 kg	31 kg	31.8 kg
Nom. amp. consumption:	1.72 A	2.10 A	1.73 A
Power supply:	3 x 400 V, 50 Hz		
Start:	Manual/direct		

### Limitations:

- Max. air volume 1600-1800 m<sup>3</sup>/h
- Paper, cardboard up to 600g/m<sup>2</sup>
- Plastic up to 0.6 mm

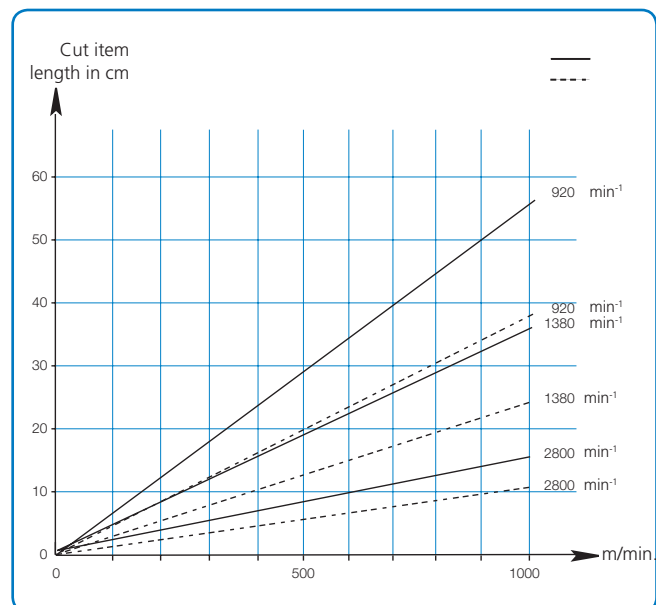

Cut item length is achieved by selection of cutter type with 2 or 3 blades and choice of motor speed. Strip speed must be known. Cut item length can vary. The lengths stated are examples. Please refer to technical data in the preceding column.